



TS432/432A/432B

Adjustable Precision Shunt Regulator

TO-92

SOT-89

SOT-23

SOT-25



Sink Current Capability up to 100mA

General Description

The TS432/432A/432B is a three-terminal adjustable shunt regulator with specified thermal stability. The output voltage may be set to any value between V_{ref} (approximately 1.24V) and 18V with two external resistors. The TS432/432A/432B has a typical output impedance of 0.2Ω. Active output circuitry provides a very sharp turn-on characteristic, making the TS432/432A/432B excellent replacement for zener diode in many applications.

This series is offered in 3-pin TO-92, SOT-89, SOT-23 and 5-pin SOT-25 package.

Features

- ◇ Precision Reference Voltage
 - TS432 1.24V±2%
 - TS432A 1.24V±1%
 - TS432B 1.24V±0.5%
- ◇ Minimum Cathode Current for regulation: 150uA(typ)
- ◇ Equivalent Full Range Temp. Coefficient: 50ppm/°C
- ◇ Programmable Output Voltage up to 18V
- ◇ Fast Turn-On Response
- ◇ Sink Current Capability of 1.0 to 100 mA
- ◇ Low Dynamic Output Impedance: 0.2Ω
- ◇ Low Output Noise

Standard Application

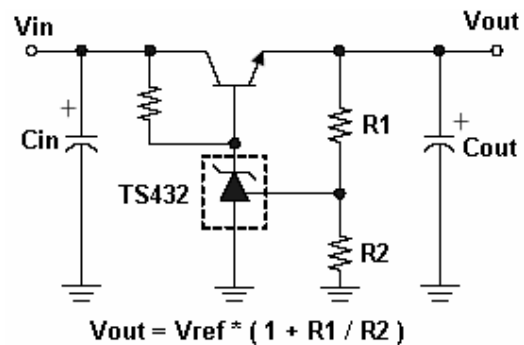

Ordering Information

Part No.	Operating Temp. (Ambient)	Package
TS432xCT	-20 ~ +85 °C	TO-92
TS432xCY		SOT-89
TS432xCX		SOT-23
TS432xCX5		SOT-25

Note: Where **x** denotes voltage tolerance.

Blank: ±2%

A: ±1%

B: ±0.5%

Block Diagram

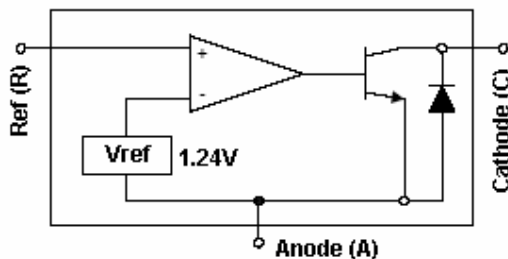

Pin Assignment

Pin No.				Pin Description
TS432/A/BCT	TS432/A/BCY	TS432/A/BCX	TS432/A/BCX5	
1	1	1	4	Reference
2	2	3	5	Anode
3	3	2	3	Cathode
			1, 2	Non connect



Absolute Maximum Rating							
Cathode Voltage (Note 1)		Vka	20	V			
Continuous Cathode Current Range		Ik	-10 ~ 200	mA			
Reference Input Current Range		Iref	10	mA			
Power Dissipation (Note 2, 3)	TO-92	Pd	0.625	W			
	TO-89		0.5				
	SOT-23 / SOT-25		0.3				
Operating Junction Temperature Range		Tj	0 ~ +125	°C			
Storage Temperature Range		T _{STG}	-65 ~ +150	°C			
Note 1: Voltage values are with respect to the anode terminal unless otherwise noted.							
Note 2: Tj Max = 150 °C							
Note 3: Rating apply to ambient temperature at 25 °C							
Recommend Operating Condition							
Cathode Voltage Range		Vka	Ref ~ 18	V			
Cathode Current Range (for regulation)		Ik	1 ~ 100	mA			
Electrical Characteristics							
(Ta=25 °C, unless otherwise specified.)							
Parameter		Symbo	Test Conditions	Min	Typ	Max	Unit
Reference voltage	TS432	Vref	Vka =Vref, Ik=10mA (Figure 1)	1.215	1.240	1.264	V
	TS432A			1.227		1.252	
	TS432B			1.233		1.246	
Deviation of reference input voltage, over temp. (Note 4)		Vref	Ta = full range Vka =Vref, Ik=10mA (Figure 1)	--	5	20	mV
Reference Input current		Iref	R1=10KΩ, R2=∞, Ika=10mA (Figure 2)	--	0.15	4.0	uA
Radio of change in Vref to change in cathode Voltage		$\Delta V_{ref} / \Delta V_{ka}$	Ika=10mA, Vka = 18V to Vref (Figure 2)	--	-1.0	-2.7	mV/V
Deviation of reference input current, over temp.		Iref(DEV)	Ta= full range R1=10KΩ, R2=∞, Ika=10mA (Figure 2)	--	0.1	4.0	uA
Minimum operating cathode current		Ika(min)	Vka=Vref (Figure 1)	--	60	200	uA
Off-state Cathode Current		Ioff	Vref=0V (Figure 3) Vka=18V	--	0.5	2.0	uA
Dynamic Output Impedance		Zka	f<1KHz, Vka=Vref Ika=100uA to 15mA (Figure 1)	--	0.2	0.5	Ω

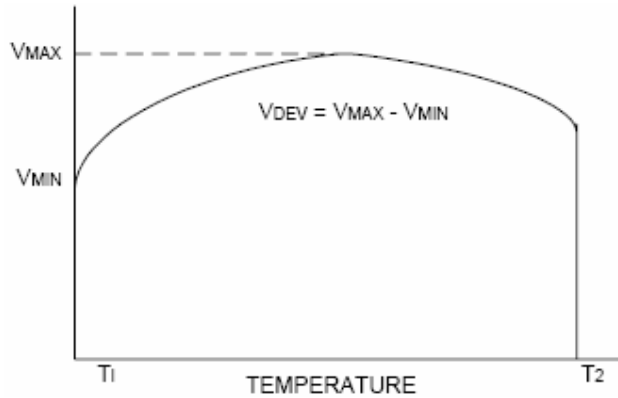

Note 4. Deviation of reference input voltage, V_{DEV} , is defined as the maximum deviation of the reference over the full temperature range.

The average temperature coefficient of the reference input voltage αV_{ref} is defined as:

$$|\alpha V_{ref}| = [V_{DEV} / V_{ref}(25)] * 10^6 / T2 - T1 \dots\dots\dots (PPM/^\circ C)$$

Where: $T2-T1$ = full temperature change.

αV_{ref} can be positive or negative depending on whether the slope is positive or negative.

Note 5. The dynamic output impedance, R_z , is defined as:

$$|Z_{ka}| = \Delta V_{ka} / \Delta I_{ka}$$

When the device is programmed with two external resistors $R1$ and $R2$ (see Figure 2). The dynamic output impedance of the overall circuit, is defined as :

$$|Z_{ka}| = \Delta v / \Delta i \approx Z_{ka} | * (1 + R1 / R2)$$

Test Circuits

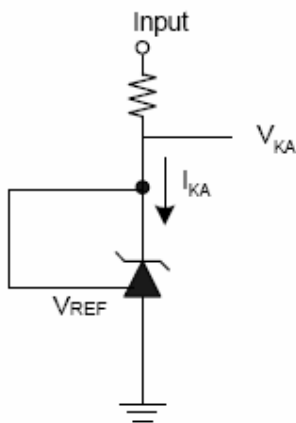
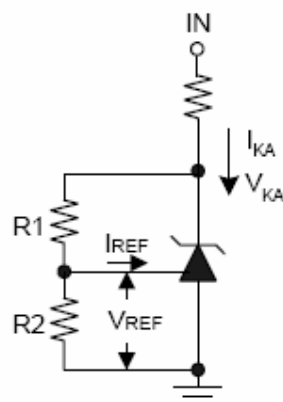

Figure 1. $V_{ka} = V_{ref}$



$$V_{ka} = V_{ref}(1 + R1/R2) + I_{ref} * R1$$

Figure 2. $V_{ka} > V_{ref}$

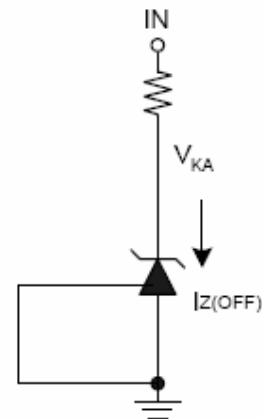
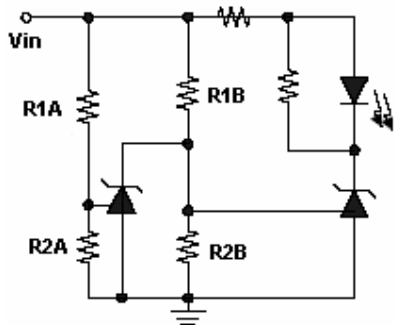

Figure 3. Off-state Current

Application Examples



LED on when $\text{low limit} < V_{in} < \text{high limit}$
 $\text{low limit} = V_{ref} (1 + R_{1B} / R_{2B})$
 $\text{high limit} = V_{ref} (1 + R_{1A} / R_{2A})$

Figure 4. Voltage Monitor

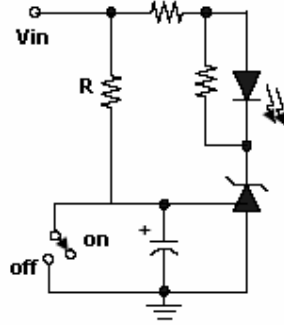

$\text{Delay} = RC \cdot \ln (V_{in} / V_{in} - V_{ref})$

Figure 5. Delay Timer

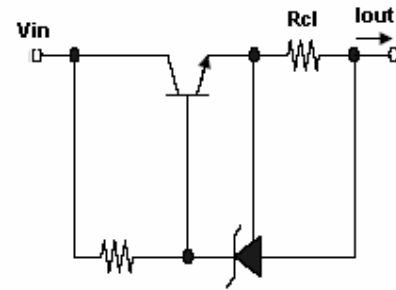

$I_{out} = V_{ref} / R_{cl}$

Figure 6. Current limiter or Current Source

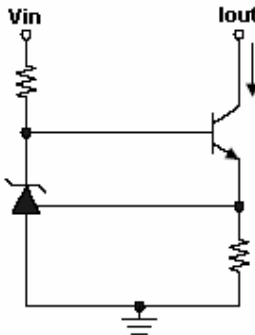

$I_{out} = V_{ref} / R_s$

Figure 7. Constant Current Sink

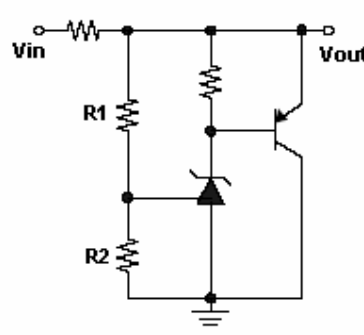

$V_{out} = V_{ref} \cdot (1 + R_1 / R_2)$

Figure 8. Higher Current Shunt

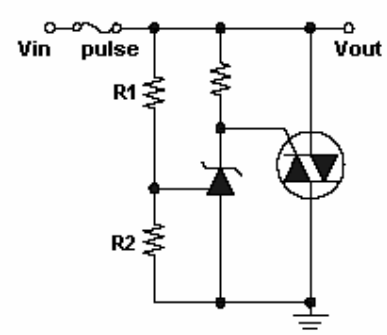

$\text{Limit} = V_{ref} \cdot (1 + R_1 / R_2)$

Figure 9. Crow Bar

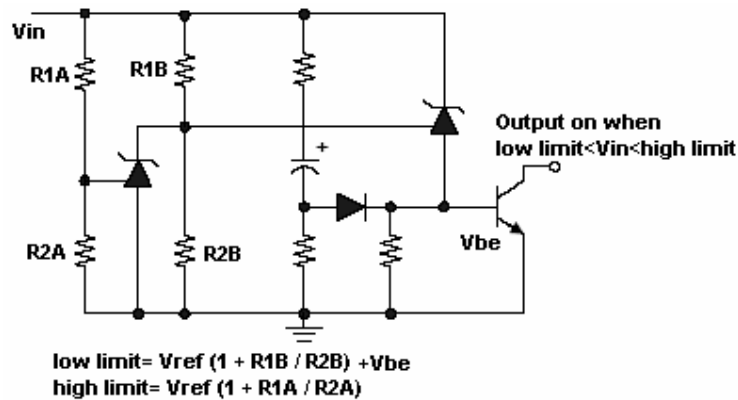

$\text{low limit} = V_{ref} (1 + R_{1B} / R_{2B}) + V_{be}$
 $\text{high limit} = V_{ref} (1 + R_{1A} / R_{2A})$

Figure 10. Under voltage protection & Over voltage circuit

Typical Performance Characteristics

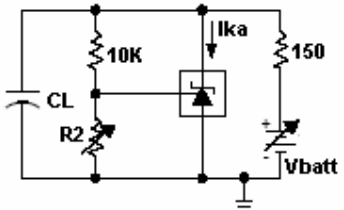
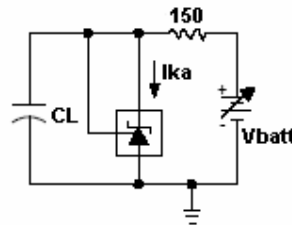
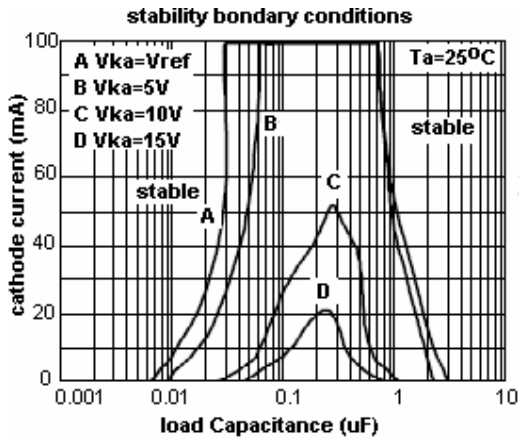
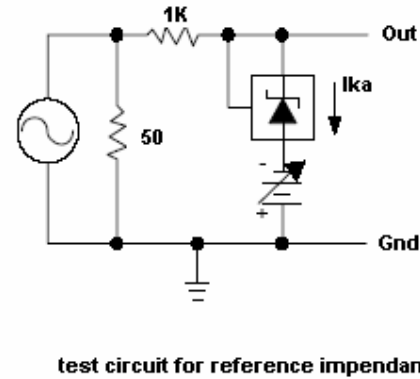
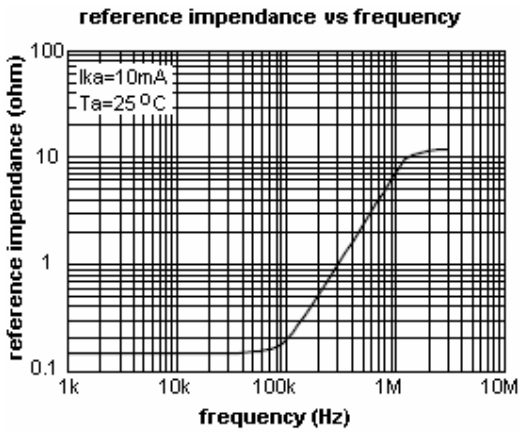
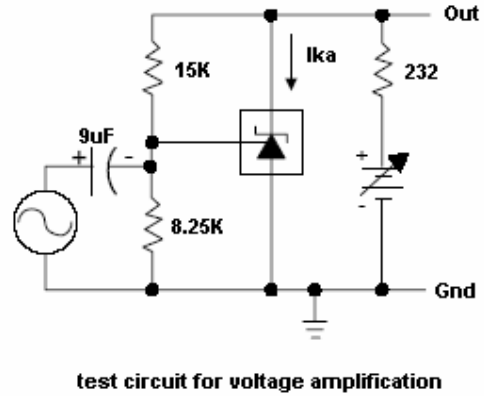
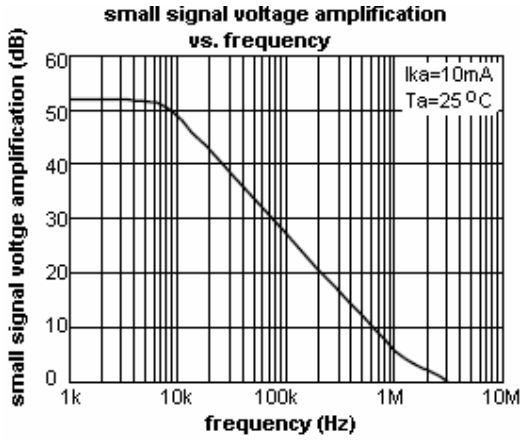

the area under the curves represent conditions that may cause the device to oscillate. for curves B, C and D, R_2 and V_+ were adjusted to establish the initial V_{ka} and I_{ka} conditions with $C_L=0$. V_{batt} and C_L were then adjusted to determine the ranges of stability.

TO-92 Mechanical Drawing

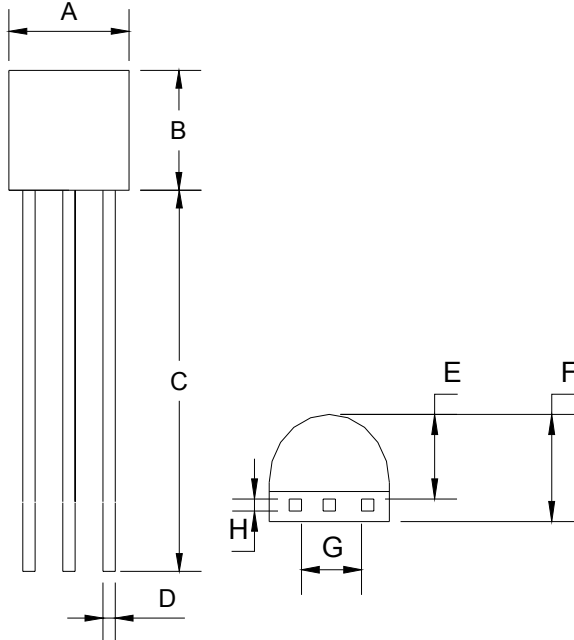

TO-92 DIMENSION				
DIM	MILLIMETERS		INCHES	
	MIN	MAX	MIN	MAX
A	4.30	4.70	0.169	0.185
B	4.30	4.70	0.169	0.185
C	14.30(typ)		0.563(typ)	
D	0.43	0.49	0.017	0.019
E	2.19	2.81	0.086	0.111
F	3.30	3.70	0.130	0.146
G	2.42	2.66	0.095	0.105
H	0.37	0.43	0.015	0.017

SOT-89 Mechanical Drawing

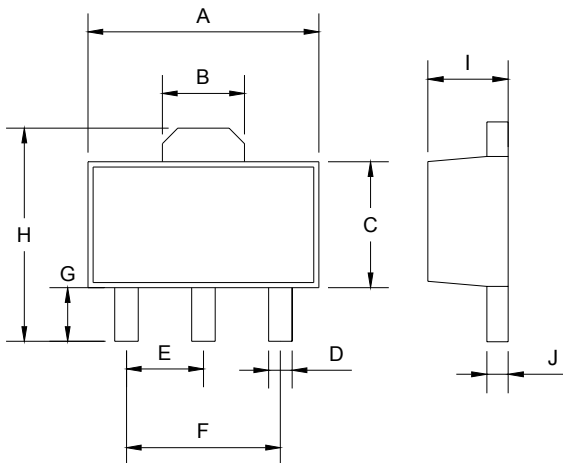

SOT-89 DIMENSION				
DIM	MILLIMETERS		INCHES	
	MIN	MAX	MIN	MAX
A	4.40	4.60	0.173	0.181
B	1.50	1.7	0.059	0.070
C	2.30	2.60	0.090	0.102
D	0.40	0.52	0.016	0.020
E	1.50	1.50	0.059	0.059
F	3.00	3.00	0.118	0.118
G	0.89	1.20	0.035	0.047
H	4.05	4.25	0.159	0.167
I	1.4	1.6	0.055	0.068
J	0.35	0.44	0.014	0.017

SOT-23 Mechanical Drawing

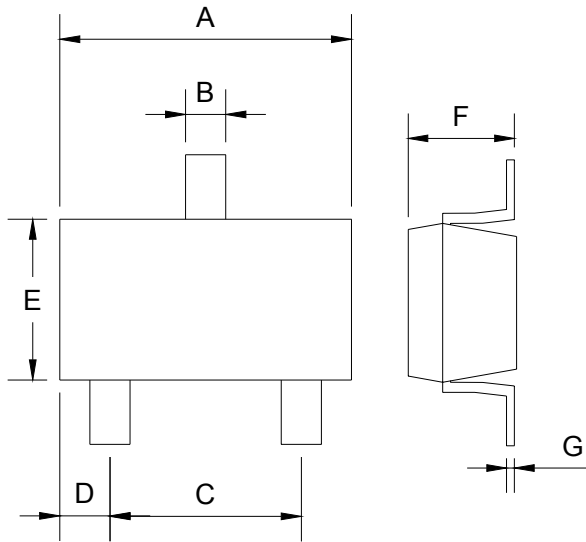

SOT-23 DIMENSION				
DIM	MILLIMETERS		INCHES	
	MIN	MAX	MIN	MAX
A	2.88	2.91	0.113	0.115
B	0.39	0.42	0.015	0.017
C	1.78	2.03	0.070	0.080
D	0.51	0.61	0.020	0.024
E	1.59	1.66	0.063	0.065
F	1.04	1.08	0.041	0.043
G	0.07	0.09	0.003	0.004

SOT-25 Mechanical Drawing

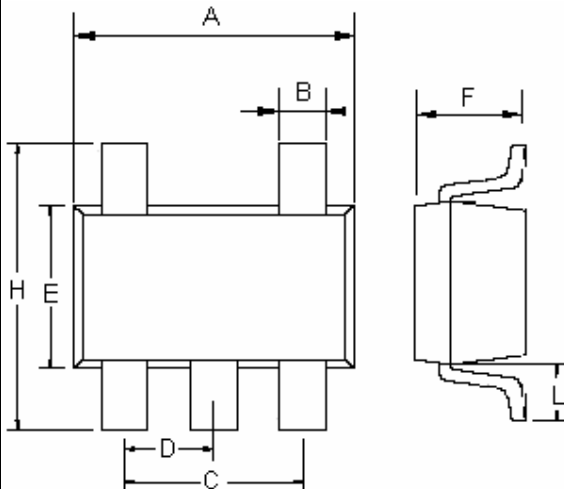

SOT-25 DIMENSION				
DIM	MILLIMETERS		INCHES	
	MIN	MAX	MIN	MAX
A	2.70	3.00	0.106	0.118
B	0.25	0.50	0.010	0.020
C	1.90(typ)		0.075(typ)	
D	0.95(typ)		0.037(typ)	
E	1.50	1.70	0.059	0.067
F	1.05	1.35	0.041	0.053
H	2.60	3.00	0.102	0.118
L	0.60(typ)		0.024(typ)	