

UNIVERSAL 4-BIT SHIFT REGISTER

DESCRIPTION

The T54LS195A/T74LS195A is high speed 4-Bit Shift Register offering typical shift frequencies of 50 MHz. It is useful for a wide variety of register and counting application. It utilized the Schottky diode clamped process to achieve high speeds and is fully compatible with all SGS TTL product.

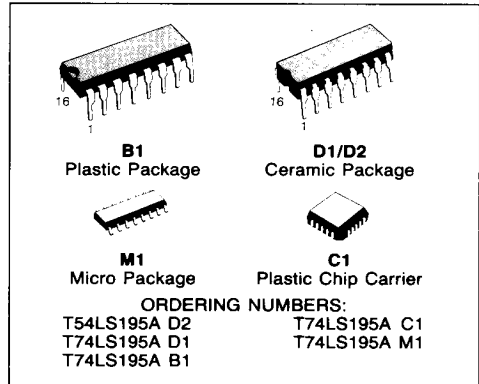

- TYPICAL SHIFT REGISTER FREQUENCY OF 40 MHz
- ASYNCHRONOUS MASTER RESET
- J,K INPUTS TO FIRST STAGE
- FULLY SYNCHRONOUS SERIAL OR PARALLEL DATA TRANSFERS
- INPUT CLAMP DIODES LIMIT HIGH SPEED TERMINATION EFFECTS
- FULLY TTL AND CMOS COMPATIBLE

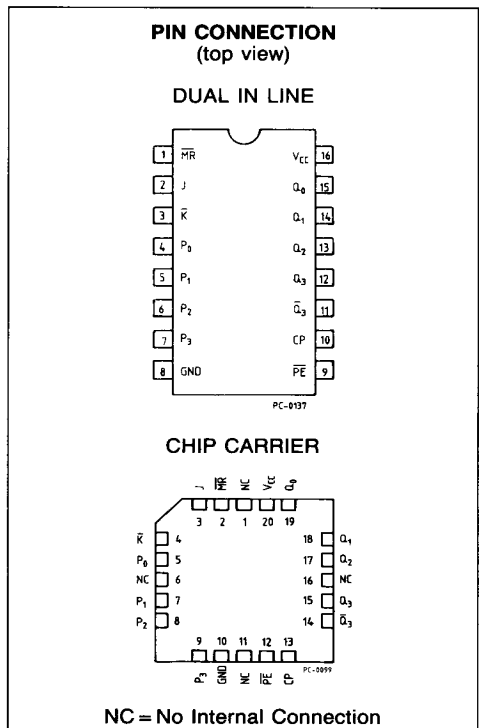

PIN NAMES

\overline{PE}	Parallel Enable (Active LOW) input
P_0 - P_3	Parallel Data Inputs
J	First Stage J (Active HIGH) Input
\overline{K}	First Stage K (Active LOW) Input
CP	Clock (Active HIGH Going Edge) Input
\overline{MR}	Master Reset (Active LOW) Input
Q_0 - Q_3	Parallel Outputs
\overline{Q}_3	Complementary Last Stage Output

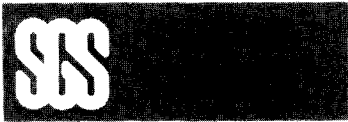

LOGIC SYMBOL AND LOGIC DIAGRAM

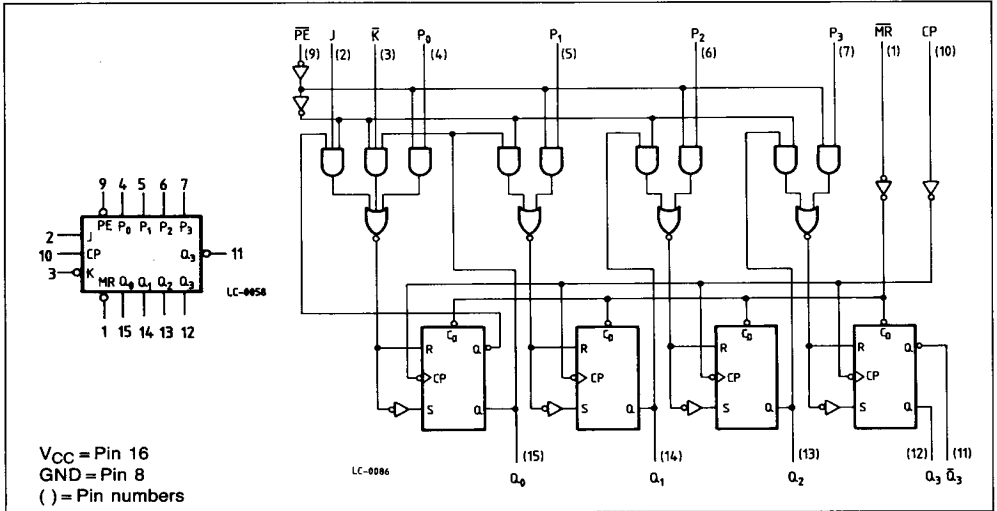

ABSOLUTE MAXIMUM RATINGS

Symbol	Parameter	Value	Unit
V_{CC}	Supply Voltage	- 0.5 to 7	V
V_I	Input Voltage, Applied to Input	- 0.5 to 15	V
V_O	Output Voltage, Applied to Output	- 0.5 to 10	V
I_I	Input Current, Into Inputs	- 30 to 5	mA
I_O	Output Current, Into Outputs	30	mA

Stresses in excess of those listed under "Absolute Maximum Ratings" may cause permanent damage to the device. This is a stress rating only and functional operation of the device at these or any other conditions in excess of those indicated in the operational sections of this specification is not implied. Exposure to absolute maximum rating conditions for extended periods may affect device reliability.

GUARANTEED OPERATING RANGES

Part Numbers	Supply Voltage			Temperature
	Min	Typ	Max	
T54LS195AD2	4.5 V	5.0 V	5.5 V	- 55°C to + 125°C
T74LS195AXX	4.75 V	5.0 V	5.25 V	0°C to + 70°C

XX = package type.

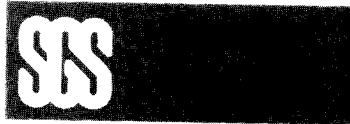

TRUTH TABLE

OPERATINGS	INPUTS					OUTPUTS				
	\overline{MR}	\overline{PE}	J	\overline{K}	P_n	Q_0	Q_1	Q_2	Q_3	$\overline{Q_3}$
Asynchronous Reset	L	X	X	X	X	L	L	L	L	H
Shift, Set First Stage	H	h	h	h	X	H	q_0	q_1	q_2	$\overline{q_2}$
Shift, Reset First Stage	H	h	l	l	X	\overline{L}	q_0	q_1	q_2	$\underline{q_2}$
Shift, Toggle First Stage	H	h	h	l	X	$\overline{q_0}$	q_0	q_1	q_2	$\underline{q_2}$
Shift, Retain First Stage	H	h	l	h	X	q_0	q_0	q_1	q_2	$\underline{q_2}$
Parallel Load	H	l	X	X	P_n	p_0	p_1	p_2	p_3	$\overline{p_3}$

L = LOW Voltage Level

H = HIGH Voltage Level

X = Don't Care

l = LOW voltage level one set-up time prior to the LOW to HIGH clock transition

h = HIGH voltage level one set-up time prior to the LOW to HIGH clock transition

P_n (q_n) = Lower case letters indicate the state of the referenced input (or output) one set-up time prior to the LOW to HIGH clock transition.

FUNCTIONAL DESCRIPTION

The Logic Diagram and Truth Table indicate the functional characteristics of the LS195A Shift register. The device is useful in a wide variety of shifting, counting and storage applications. It performs serial, parallel, serial to parallel, or parallel to serial data transfers at very high speeds.

The LS195A has not two primary modes of operation, shift right ($Q_0 \rightarrow Q_1$) and parallel load which are controlled by the state of the Parallel Enable (\overline{PE}) input. When the \overline{PE} input is HIGH, serial data enters the first flip-flop Q_0 via the J and \overline{K} inputs and is shifted one bit in the direction $Q_0 \rightarrow Q_1 \rightarrow Q_2 \rightarrow Q_3$ following each LOW to HIGH clock transition. The JK inputs provide the flexibility of the JK type input for special applications, and the simple D type in-

put for general applications by tying the two pins together. When the \overline{PE} input is LOW, the LS195A appears as four common clocked D flip-flop. The data on the parallel inputs P_0, P_1, P_2, P_3 is transferred to the respective Q_0, Q_1, Q_2, Q_3 outputs to the P_{n-1} inputs and holding the \overline{PE} input LOW. All serial and parallel data transfers are synchronous, occurring after each LOW to HIGH clock transition. Since the LS195A utilizes edge-triggering, there is no restriction on the activity of the J, K, P_n and \overline{PE} inputs for logic operation - except for the set-up and release time requirements.

A LOW on the asynchronous Master Reset (\overline{MR}) input sets all Q outputs LOW, independent of any other input condition.

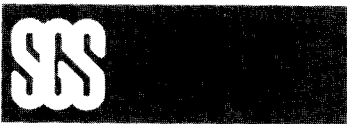

DC CHARACTERISTICS OVER OPERATING TEMPERATURE RANGE

Symbol	Parameter		Limits			Test Conditions (Note 1)	Units	
			Min.	Typ.	Max.			
V _{IH}	Input HIGH Voltage		2.0			Guaranteed input HIGH Voltage for all Inputs	V	
V _{IL}	Input LOW Voltage	54			0.7	Guaranteed input LOW Voltage for all Inputs	V	
		74			0.8			
V _{CD}	Input Clamp Diode Voltage			-0.65	-1.5	V _{CC} = MIN, I _{IN} = -18mA	V	
V _{OH}	Output HIGH Voltage	54	2.5	3.4		V _{CC} = MIN, I _{OH} = -400μA, V _{IN} = V _{IH} or V _{IL} per Truth Table	V	
		74	2.7	3.4				
V _{OL}	Output LOW Voltage	54,74		0.25	0.4	I _{OL} = 12mA I _{OL} = 24mA	V _{CC} = MIN, V _{IN} = V _{IH} or V _{IL} per Truth Table	V
		74		0.35	0.5			
I _{IH}	Input HIGH Current				20 0.1	V _{CC} = MAX, V _{IN} = 2.7V V _{CC} = MAX, V _{IN} = 7.0V	μA	
I _{IL}	Input LOW Current				-0.4	V _{CC} = MAX, V _{IN} = 0.4V	mA	
I _{OS}	Output Short Circuit Current (Note 2)		-20		-100	V _{CC} = MAX, V _{OUT} = 0V	mA	
I _{CC}	Power Supply Current			14	21	V _{CC} = MAX	mA	

AC CHARACTERISTICS: T_A = 25°C

Symbol	Parameter		Limits			Test Conditions	Units	
			Min.	Typ.	Max.			
f _{MAX}	Shift Frequency		30	40		Fig. 1	V _{CC} = 5.0V C _L = 15pF	ns
t _{PLH}	Propagation Delay, Clock to Output		14	22		Fig. 1		ns
t _{PHL}		Propagation Delay, MR to Output		19	30			Fig. 3

Notes:

- 1) Conditions for testing, not shown in the Table, are chosen to guarantee operation under "worst case" conditions.
- 2) Not more than one output should be shorted at a time.
- 3) Typical values are at V_{CC} = 5.0V, T_A = 25°C

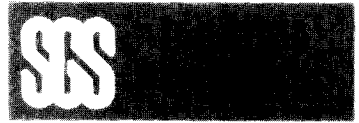

AC SET-UP REQUIREMENTS: $T_A = 25^\circ\text{C}$

Symbol	Parameter	Limits			Test Conditions	Units
		Min.	Typ.	Max.		
$t_W(\text{CP})$	Clock Pulse Width	16	7		Fig. 1	$V_{CC} = 5.0\text{V}$ $C_L = 15\text{pF}$
$t_s(\text{Data})$	Set-up Time Data to Clock	15	11		Fig. 2	
$t_h(\text{Data})$	Hold Time Data to Clock	0				
$t_s(\text{S})$	Set-up Time $\overline{\text{PE}}$ Control to Clock	25	18		Fig. 4	
$t_h(\text{S})$	Hold Time $\overline{\text{PE}}$ Control to Clock	0				
$t_W(\overline{\text{MR}})$	Master Reset Pulse Width	12	8		Fig. 3	
$t_{\text{rec}}(\overline{\text{MR}})$	Recovery Time Master Reset to Clock	25	6			
t_{release}	$\overline{\text{PE}}$			10		

DEFINITION OF TERMS:

SET-UP TIME (t_s) - is defined as the minimum time required for the correct logic level to be present at the logic input prior to the clock transition from LOW to HIGH in order to be recognized and transferred to the outputs.

HOLD TIME (t_h) - is defined as the minimum time following the clock transition from LOW to HIGH that the logic level must be maintained at the input in order to ensure continued recognition. A negative HOLD TIME indicates that the correct logic level may be released prior to the clock transition from LOW to HIGH and still be recognized.

RECOVERY TIME (t_{rec}) - is defined as the minimum time required between the end of the reset pulse and the clock transition from LOW to HIGH in order to be recognized and transfer HIGH Data to the Q outputs.

AC WAVEFORMS

The shaded areas indicate when the input is permitted to change for predictable output performance.

Fig. 1 Clock to Output Delays and Clock Pulse Width

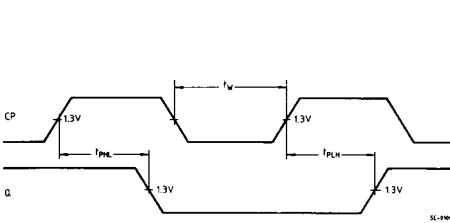

Conditions: $J = \overline{\text{PE}} = \overline{\text{MR}} = H$
 $K = L$

Fig. 2 Set-up (t_s) and Hold (t_h) Time for Serial Data (J & K) and Parallel Data (P_0, P_1, P_2, P_3)

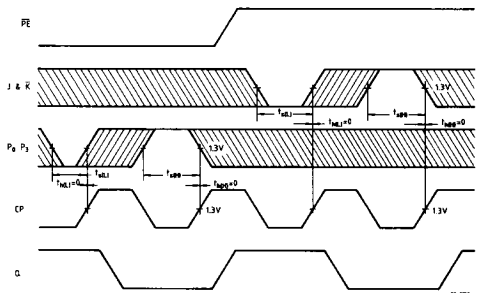

Conditions: $\overline{\text{MR}} = H$
* J and K set-up time affects Q_0 only



AC WAVEFORMS (continued)

Fig. 3 Master Reset Pulse Width, Master Reset to Output Delay and Master Reset to Clock Recovery Time

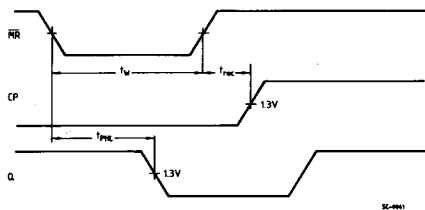

Other Conditions: $\overline{PE} = L$
 $P_0 = P_1 = P_2 = P_3 = H$

Fig. 4 Set-up (t_s) and Hold (t_h) Time for \overline{PE} Input

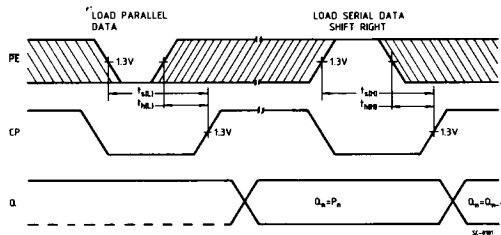

Conditions: $\overline{MR} = H$
 * Q_0 state will be determined by J and \overline{K} input