



## DUAL 1-OF-4 DECODER

### DESCRIPTION

The T54LS139/T74LS139 is a high speed Dual 1-of-4 Decoder/Demultiplexer. This device has two independent decoders, each accepting two inputs and providing four mutually exclusive active LOW outputs. Each decoder has an active LOW Enable input which can be used as a data input for a 4-output demultiplexer. Each half of the LS139 can be used as a function generator providing all four minterms of two variables. The LS139 is fabricated with the Schottky barrier diode process for high speed and is completely compatible with all SGS TTL families.

- SCHOTTKY PROCESS FOR HIGH SPEED
- MULTIFUNCTION CAPABILITY
- TWO COMPLETELY INDEPENDENT 1-OF-4 DECODERS
- ACTIVE LOW MUTUALLY EXCLUSIVE OUTPUTS
- INPUT CLAMP DIODES LIMIT HIGH SPEED TERMINATION EFFECTS
- FULLY TTL AND CMOS COMPATIBLE

### PIN NAMES

|                       |                           |
|-----------------------|---------------------------|
| $A_0-A_1$             | Address Inputs            |
| $\bar{E}$             | Enable (Active LOW) Input |
| $\bar{O}_0-\bar{O}_3$ | Active LOW Outputs        |

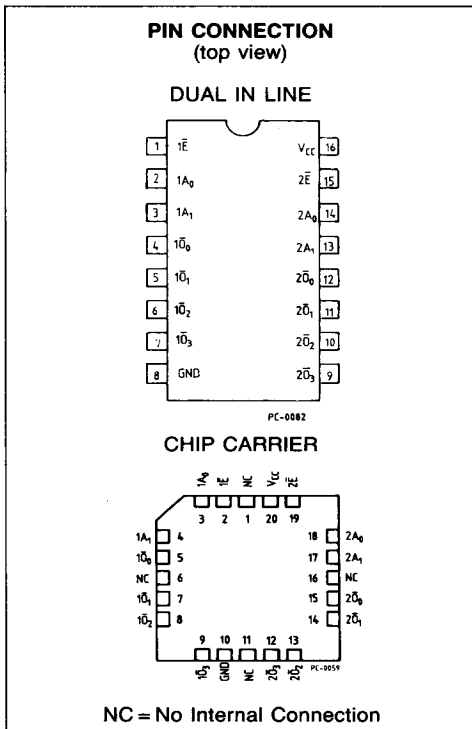
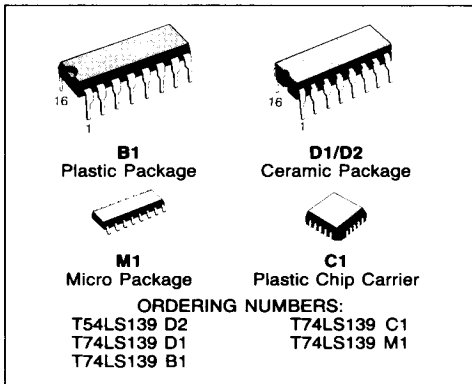



## LOGIC SYMBOL AND LOGIC DIAGRAM

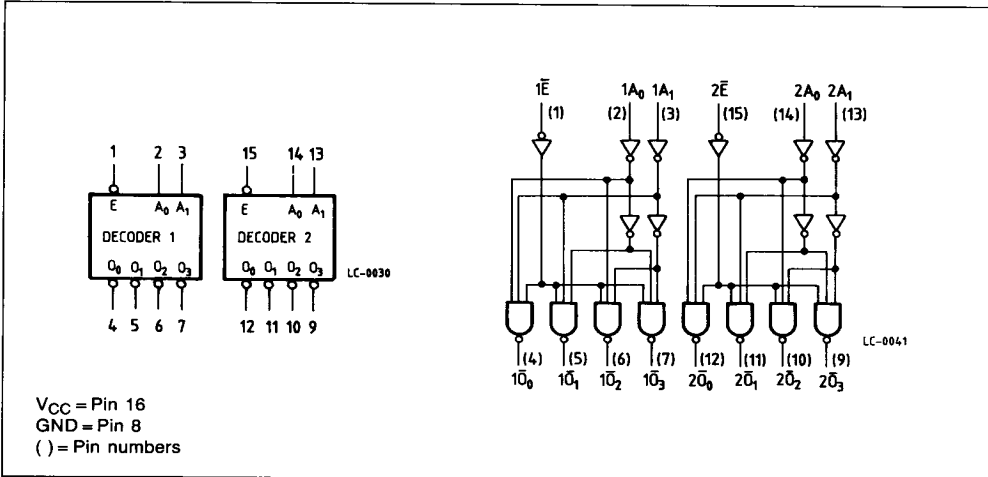

## ABSOLUTE MAXIMUM RATINGS

| Symbol   | Parameter                         | Value      | Unit |
|----------|-----------------------------------|------------|------|
| $V_{CC}$ | Supply Voltage                    | -0.5 to 7  | V    |
| $V_I$    | Input Voltage, Applied to Input   | -0.5 to 15 | V    |
| $V_O$    | Output Voltage, Applied to Output | -0.6 to 10 | V    |
| $I_I$    | Input Current, Into Inputs        | -30 to 5   | mA   |
| $I_O$    | Output Current, Into Outputs      | 50         | mA   |

Stresses in excess of those listed under "Absolute Maximum Ratings" may cause permanent damage to the device. This is a stress rating only and functional operation of the device at these or any other conditions in excess of those indicated in the operational sections of this specification is not implied. Exposure to absolute maximum rating conditions for extended periods may affect device reliability.

## GUARANTEED OPERATING RANGES

| Part Numbers | Supply Voltage |       |        | Temperature     |
|--------------|----------------|-------|--------|-----------------|
|              | Min            | Typ   | Max    |                 |
| T54LS139D2   | 4.5 V          | 5.0 V | 5.5 V  | -55°C to +125°C |
| T74LS139XX   | 4.75 V         | 5.0 V | 5.25 V | 0°C to +70°C    |

XX = package type.

### FUNCTIONAL DESCRIPTION

The LS139 is a high speed dual 1-of-4 Decoder/Demultiplexer fabricated with the Schottky barrier diode process. The device has two independent decoders, each of which accept two binary weighted inputs ( $A_0$ - $A_1$ ) and provide four mutually exclusive active LOW outputs ( $\bar{O}_0$ - $\bar{O}_3$ ). Each decoder has an active LOW Enable ( $\bar{E}$ ). When  $\bar{E}$  is HIGH all output are forced HIGH.

### TRUTH TABLE

| INPUTS    |       |       | OUPUTS      |             |             |             |
|-----------|-------|-------|-------------|-------------|-------------|-------------|
| $\bar{E}$ | $A_0$ | $A_1$ | $\bar{O}_0$ | $\bar{O}_1$ | $\bar{O}_2$ | $\bar{O}_3$ |
| H         | X     | X     | H           | H           | H           | H           |
| L         | L     | L     | L           | H           | H           | H           |
| L         | H     | L     | H           | L           | H           | H           |
| L         | L     | H     | H           | H           | L           | H           |
| L         | H     | H     | H           | H           | H           | L           |

H = HIGH Voltage Level  
 L = LOW Voltage Level  
 X = Don't Care

The enable can be used as the data input for a 4-output demultiplexer application.

Each half of the LS139 generates all four minterms of two variables. These four minterms are useful in some applications, replacing multiple gate functions as shown in Fig. 1, and thereby reducing the number of packages required in a logic network.

Fig. 1

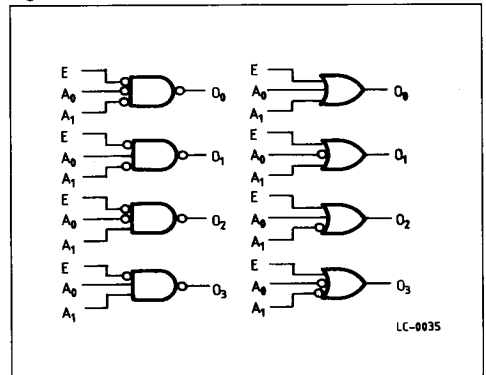

### AC WAVEFORMS

Fig. 2

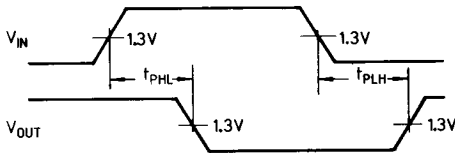

SC-0009

Fig. 3

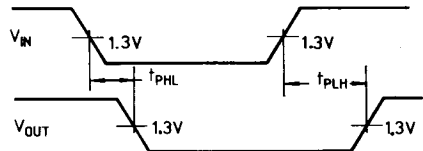

SC-0007



### DC CHARACTERISTICS OVER OPERATING TEMPERATURE RANGE

| Symbol   | Parameter                                |       | Limits |       |           | Test Conditions<br>(Note 1)   | Units   |   |
|----------|--|-------|--------|-------|-----------|---|---|---|
|          |  |       | Min.   | Typ.  | Max.      |   |   |   |
| $V_{IH}$ | Input HIGH Voltage                       |       | 2.0    |       |           | Guaranteed input HIGH Tresh.<br>Voltage for all Inputs  | V   |   |
| $V_{IL}$ | Input LOW Voltage                        | 54    |        |       | 0.7       | Guaranteed input LOW Tresh.<br>Voltage for all Inputs   | V   |   |
|          |  | 74    |        |       | 0.8       |   |   |   |
| $V_{CD}$ | Input Clamp Diode Voltage                |       |        | -0.65 | -1.5      | $V_{CC} = \text{MIN}, I_{IN} = -18\text{mA}$  | V   |   |
| $V_{OH}$ | Output HIGH Voltage                      | 54    | 2.5    | 3.4   |           | $V_{CC} = \text{MIN}, I_{OH} = -400\mu\text{A}, V_{IN} = V_{IH}$ or<br>$V_{IL}$ per Truth Table | V   |   |
|          |  | 74    | 2.7    | 3.4   |           |   |   |   |
| $V_{OL}$ | Output LOW Voltage                       | 54,74 |        | 0.25  | 0.4       | $I_{OL} = 4.0\text{mA}$<br>$I_{OL} = 8.0\text{mA}$  | $V_{CC} = \text{MIN}, V_{IN} = V_{IH}$ or<br>$V_{IL}$ per Truth Table | V |
|          |  | 74    |        | 0.35  | 0.5       |   |   |   |
| $I_{IH}$ | Input HIGH Current                       |       |        | 1.0   | 20<br>0.1 | $V_{CC} = \text{MAX}, V_{IN} = 2.7\text{V}$<br>$V_{CC} = \text{MAX}, V_{IN} = 7.0\text{V}$      | $\mu\text{A}$<br>mA   |   |
| $I_{IL}$ | Input LOW Current                        |       |        |       | -0.36     | $V_{CC} = \text{MAX}, V_{IN} = 0.4\text{V}$   | mA  |   |
| $I_{OS}$ | Output Short Circuit Current<br>(Note 2) |       | -20    |       | -100      | $V_{CC} = \text{MAX}, V_{OUT} = 0\text{V}$  | mA  |   |
| $I_{CC}$ | Power Supply Current                     |       |        | 7.0   | 11        | $V_{CC} = \text{MAX}$   | mA  |   |

### AC CHARACTERISTICS: $T_A = 25^\circ\text{C}$

| Symbol    | Parameter                               | Level of Delay | Limits |      |      | Test Conditions                               | Units |
|-----------|---|----------------|--------|------|------|---|-------|
|           |   |                | Min.   | Typ. | Max. |   |       |
| $t_{PLH}$ | Propagation Delay,<br>Address to Output | 2              |        | 13   | 20   | $V_{CC} = 5.0\text{V}$<br>$C_L = 15\text{pF}$ | ns    |
| $t_{PHL}$ |   |                |        | 22   | 33   |   |       |
| $t_{PLH}$ | Propagation Delay,<br>Enable to Output  | 3              |        | 18   | 29   |   | ns    |
| $t_{PHL}$ |   |                |        | 25   | 38   |   |       |
| $t_{PLH}$ | Propagation Delay,<br>Enable to Output  | 2              |        | 16   | 24   |   | ns    |
| $t_{PHL}$ |   |                |        | 21   | 32   |   |       |

#### Notes:

- 1) Conditions shown as MIN or MAX, use the appropriate value specified under guaranteed operating ranges.
- 2) Not more than one output should be shorted at a time.
- 3) Typical values are at  $V_{CC} = 5.0\text{V}, T_A = 25^\circ\text{C}$