

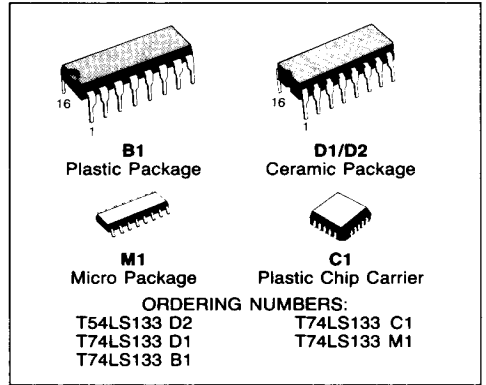

13-INPUT NAND GATE

DESCRIPTION

The T54LS133/T74LS133 is a high speed 13-INPUT NAND GATE fabricated in silicon LOW POWER SCHOTTKY technology.



PIN CONNECTION (top view)

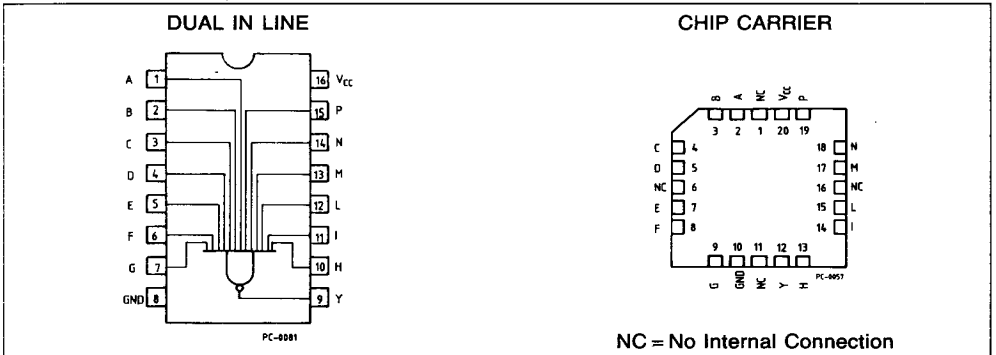

SCHEMATIC

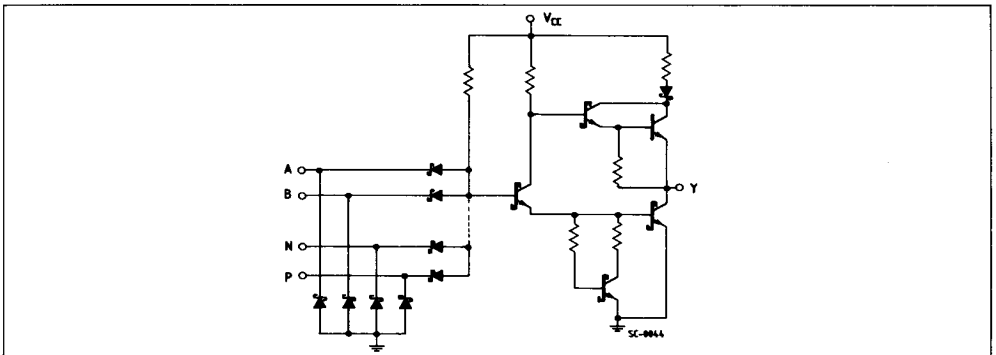



LOGIC DIAGRAM

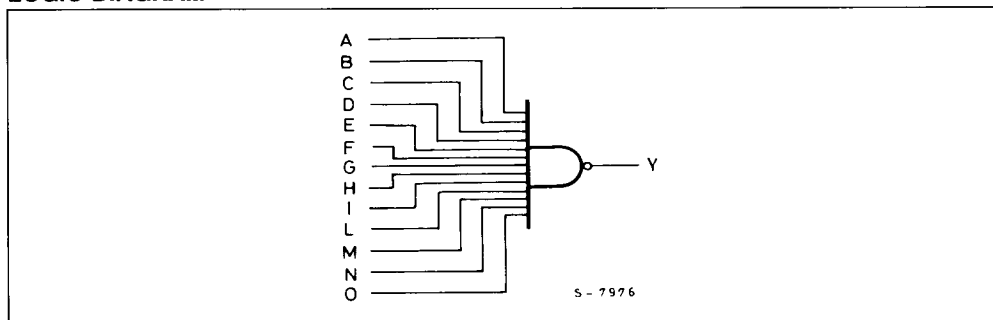

ABSOLUTE MAXIMUM RATINGS

Symbol	Parameter	Value	Unit
V_{CC}	Supply Voltage	-0.5 to 7	V
V_I	Input Voltage, Applied to Input	-0.5 to 15	V
V_O	Output Voltage, Applied to Output	-0.5 to 10	V
I_I	Input Current, Into Inputs	-30 to 5	mA
I_O	Output Current, Into Outputs	60	mA

Stresses in excess of those listed under "Absolute Maximum Ratings" may cause permanent damage to the device. This is a stress rating only and functional operation of the device at these or any other conditions in excess of those indicated in the operational sections of this specification is not implied. Exposure to absolute maximum rating conditions for extended periods may affect device reliability.

GUARANTEED OPERATING RANGES

Part Numbers	Supply Voltage			Temperature
	Min	Typ	Max	
T54LS133D2	4.5 V	5.0 V	5.5 V	-55°C to +125°C
T74LS133XX	4.75 V	5.0 V	5.25 V	0°C to +70°C

XX = package type.

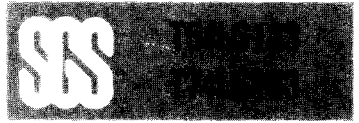

DC CHARACTERISTICS OVER OPERATING TEMPERATURE RANGE

Symbol	Parameter		Limits			Test Conditions (Note 1)	Units
			Min.	Typ.	Max.		
V _{IH}	Input HIGH Voltage		2.0			Guaranteed input HIGH Voltage	V
V _{IL}	Input LOW Voltage	54			0.7	Guaranteed input LOW Voltage	V
		74			0.8		
V _{CD}	Input Clamp Diode Voltage			-0.65	-1.5	V _{CC} = MIN, I _{IN} = -18mA	V
V _{OH}	Output HIGH Voltage	54	2.5	3.4		V _{CC} = MIN, I _{OH} = -400μA, V _{IN} = V _{IL}	V
		74	2.7	3.4			
V _{OL}	Output LOW Voltage	54,74		0.25	0.4	I _{OL} = 4.0mA V _{CC} = MIN, V _{IN} = 2.0V	V
		74		0.35	0.5		
I _{IH}	Input HIGH Current			1.0	20	V _{CC} = MAX, V _{IN} = 2.7V V _{CC} = MAX, V _{IN} = 7.0V	μA mA
I _{IL}	Input LOW Current				-0.4	V _{CC} = MAX, V _{IN} = 0.4V	mA
I _{OS}	Output Short Circuit Current (Note 2)		-20		-100	V _{CC} = MAX, V _{OUT} = 0V	mA
I _{COH}	Supply Current HIGH			0.35	0.5	V _{CC} = MAX, V _{IN} = 0V	mA
I _{CCL}	Supply Current LOW			0.6	1.1	V _{CC} = MAX, Inputs Open	mA

AC CHARACTERISTICS: T_A = 25°C (See page 576 for AC test circuit and waveforms)

Symbol	Parameter		Limits			Test Conditions	Units
			Min.	Typ.	Max.		
t _{PLH}	Turn Off Delay, Input to Output			10	15	V _{CC} = 5.0V C _L = 15pF	ns
t _{PHL}	Turn On Delay, Input to Output			25	38		ns

Notes:

- 1) For conditions shown as MIN or MAX, use the appropriate value specified under guaranteed operating ranges.
- 2) Not more than one output should be shorted at a time.
- 3) Typical values at are V_{CC} = 5.0V, T_A = 25°C