

Automotive high speed CAN bus transceiver

Datasheet - production data

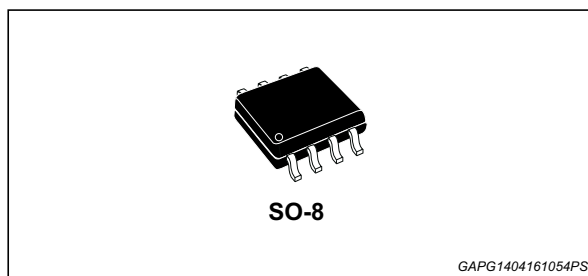

Features

- AEC-Q100 qualified
- ISO/DIS 11898 up to 1 Mbaud
- Transmitter:
 - Generation of differential output signals
 - Short circuit protected from -5 V to 36 V, detection and shutdown



- Slope control to reduce RFI and EMI
- Two states adjustable slope control (≤ 1 Mbaud / ≤ 250 Kbaud)
- Receiver:
 - Differential input with high interference suppression
 - Common mode input voltage range (V_{COM}) from -2 V to V_S+3 V
- ESD protection level up to 4 kV
- Package: SO-8

Description

The L9616 is a bidirectional transceiver for signal conditioning and processing in connection with a CAN controller. Data rates of up to 1 Mbaud are supported using either shielded or non-shielded pair of lines.

Table 1. Device summary

Order code	Package	Packing
L9616	SO-8	Tube
L9616-TR	SO-8	Tape & Reel

Contents

1	Block diagram	5
2	Pins description	6
3	Electrical specifications	7
3.1	Absolute maximum ratings	7
3.2	Electrical characteristics	7
3.3	Dynamic characteristics	9
4	Functional description	10
5	Package information	14
5.1	SO-8 package information	14
6	Revision history	16

List of tables

Table 1.	Device summary	1
Table 2.	Pins function	6
Table 3.	Absolute maximum ratings	7
Table 4.	Electrical characteristics	7
Table 5.	Dynamic characteristics	9
Table 6.	Functional table	10
Table 7.	SO-8 package mechanical data	15
Table 8.	Document revision history.	16

List of figures

Figure 1.	Block diagram	5
Figure 2.	Pins connection diagram (top view)	6
Figure 3.	Typical application	10
Figure 4.	Timing diagram	11
Figure 5.	EMC performance (receiver).	12
Figure 6.	EMC performance (transmitter)	12
Figure 7.	Transceiver without EMC reducing measures (transceiver)	13
Figure 8.	Transceiver with EMC reducing measures (transceiver)	13
Figure 9.	EMC performance (transceiver sending)	13
Figure 10.	Transceiver without EMC reducing measures (transceiver)	13
Figure 11.	Transceiver with EMC reducing measures (transceiver)	13
Figure 12.	SO-8 package outline	14

1 Block diagram

Figure 1. Block diagram

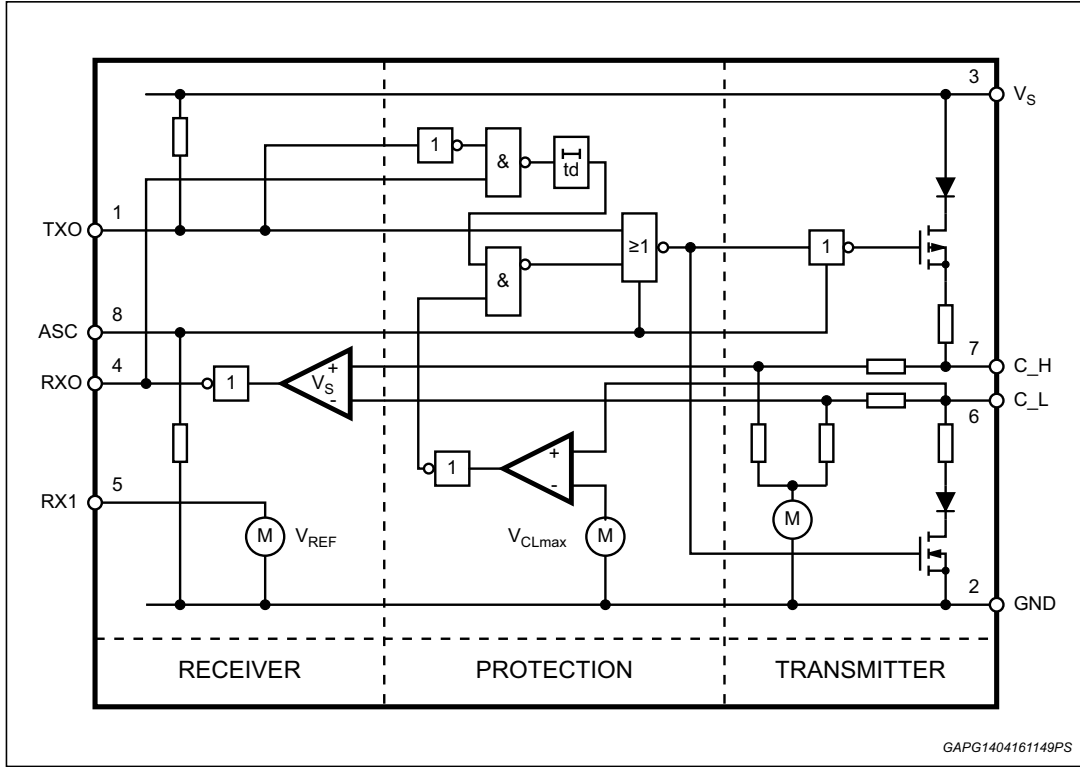

2 Pins description

Figure 2. Pins connection diagram (top view)

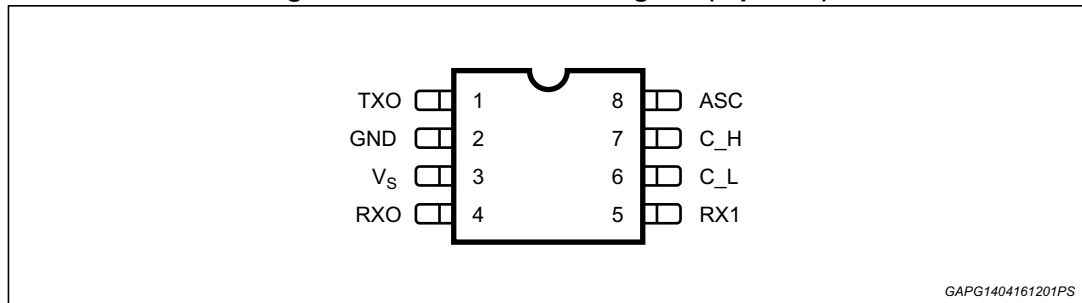

Table 2. Pins function

Pin #	Name	Function
1	TXO	Transmitter input
2	GND	Ground
3	V_S	Supply voltage
4	RXO	Receive output
5	RX1	Reference voltage
6	C_L	Low side bus output
7	C_H	High side bus output
8	ASC	Adjustable slope control

3 Electrical specifications

3.1 Absolute maximum ratings

Table 3. Absolute maximum ratings

Symbol	Parameter	Value	Unit
V_S	Supply voltage	-0.3 to 7	V
V_{C_H}, V_{C_L}	Bus voltage at C_H, C_L ($V_S = 0$ to 5.5 V)	-5 to 36	V
I_{C_H}, I_{C_L}	Off state leakage current at C_H, C_L ($V_S = 0$ to 5.5 V, $V_{C_H} = -5$ to 36 V, $V_{C_L} = -5$ to 36 V)	-3 to 5	mA
V_{DC}	DC voltage at TXO, ASC ($V_S = 0$ to 5.5 V)	GND -0.3 to $V_S + 0.3$	V
I_{RXO}	Output current at RXO ($V_S = 0$ to 5.5 V)	-0.3 to 1	mA
T_{stg}, T_J	Storage and junction temperature range	-40 to 150	°C
T_{op}	Operating temperature range	-40 to 125	°C

Note: All voltages, except bus voltage, are defined with respect to pin 2.
Positive currents flow into the IC.

3.2 Electrical characteristics

$T_{OP} = -40$ to 125 °C; $V_S = 4.5$ to 5.5 V; Dominant: $V_{TXO} = GND$; Recessive: $V_{TXO} = V_S$; All voltages, except bus voltage, are defined with respect to pin 2. Positive currents flow into the IC unless otherwise specified.

Table 4. Electrical characteristics

Symbol	Parameter	Test condition	Min.	Typ.	Max.	Unit
V_S	Supply voltage	-	4.5	5	5.5	V
I_S	Supply current	Dominant	-	-	80	mA
		Recessive	-	-	20	mA
Transmitter Section ($R_A = 60 \Omega$ between C_H and C_L)						
C_{TXO}	TXO input capacitance	$0 V < V_{TXO} < V_S$	-	25	-	pF
V_{TXO}	TXO high level input voltage	-	$0.7 V_S$	-	V_S	-
	TXO low level input voltage	-	0	-	$0.3 V_S$	-
I_{TXO}	TXO high level input current	$V_{TXO} = V_S$	-2	0	2	μA
	TXO low level input current	$V_{TXO} = GND$	-275	0	-25	μA
C_{ASC}	ASC input capacitance	$0 V < V_{ASC} < V_S$	-	25	-	pF

Table 4. Electrical characteristics (continued)

Symbol	Parameter	Test condition	Min.	Typ.	Max.	Unit
V_{ASC}	ASC input voltage for high speed	-	0	-	$0.1 V_S$	-
	ASC input voltage for low speed	-	$0.9 V_S$	-	V_S	-
I_{ASC}	ASC input current	$V_{ASC} = V_S$	25	-	275	μA
		$V_{ASC} = 0 V$	-2	0	2	μA
V_{C_H}, V_{C_L}	Bus voltage recessive	Recessive	$0.4 V_S$	$0.5 V_S$	$0.6 V_S$	-
I_{C_H}, I_{C_L}	Leakage current recessive	$V_{C_L} = V_{C_H} = -2 \text{ to } 7 V$	-0.7	-	0.7	mA
		$V_{C_L} = V_{C_H} = 1 \text{ to } 4 V$	-0.3	-	0.3	mA
$R_{IN(C_H, C_L)}$	Input resistance	Recessive	5	-	50	k Ω
$R_{Diff(C_H, C_L)}$	Differential input resistance	Recessive	10	-	100	k Ω
$V_{Diff} = V_{C_H} - V_{C_L}$	Differential output voltage	Dominant, R_A	1.5	-	3	V
		Recessive	-500	0	50	mV
t_d	Short circuit detection time C_H to C_L; C_H to B	$R_{CS} < 1 \Omega$	1	5	10	μs
I_A	Supply current in case of short circuit, C_H to C_L, C_H to B (time = t_d)	-	-	150	-	mA
V_{C_Lmax}	Overvoltage protection threshold on C_L	-	7	8	10	V
Receive section						
V_{RXO}	RXO high level output voltage	$V_{Diff} < 0.5 V$; $I_{RXO} = 0.3 \text{ mA}$; $V_{C_H} = -2 \text{ to } 7 V$; $V_{C_L} = -2 \text{ to } 7 V$;	$0.9 V_S$	-	V_S	V
-	RXO low level output voltage	$V_{Diff} > 0.9 V$; $I_{RXO} = 1 \text{ mA}$; $V_{C_H} = -2 \text{ to } 7 V$; $V_{C_L} = -2 \text{ to } 7 V$;	-	-	0.5	V
$V_S = V_{C_H} - V_{C_L}$	Input signal threshold	$V_{C_H} = -2 \text{ to } 7 V$; $V_{C_L} = -2 \text{ to } 7 V$	500	700	900	mV
$V_{COM} = (V_{C_H} + V_{C_L})/2$	Input common mode voltage range	-	-2	-	7	V
V_{HYS}	Differential input hysteresis	-	-	150	-	mV
REFERENCE OUTPUT						
V_{RX1}	Reference voltage	$I_{RX1} = 0$	$0.45 V_S$	$0.5 V_S$	$0.55 V_S$	V
R_{RX1}	Output resistance	-	2	-	9	k Ω

3.3 Dynamic characteristics

$C_A = 47$ pF between C_H and C_L; $V_S = 5$ V; $t_R < 5$ ns; $C_{RXO} = 20$ pF between RXO and B; $R_A = 60$ Ω between C_H and C_L.

Table 5. Dynamic characteristics

Symbol	Parameter	Test Condition	Min.	Typ.	Max.	Unit
t_{OT}	Signal Delay TXO to C_H, C_L	-	-	-	50	ns
S_R	Differential Output Slew Rate (Transmitter)	$V_{ASC} = 0$ V	20	-	50	V/ μ s
		$V_{ASC} = V_S$	5	-	20	V/ μ s
t_{OR}	Signal Delay C_H, C_L to RXO	$V_{ASC} = 0$ V	-	-	150	ns
t_{OTR}	Signal Delay TXO to RXO	$V_{ASC} = 0$ V	-	-	300	ns

4 Functional description

The L9616 is used as an interface between a CAN controller and the physical bus. The device provides transmitting capability to the CAN controller.

The transmitter outputs C_H and C_L are protected against short circuits and electrical transients which may occur in an automotive environment.

In case of short circuit (C_H to C_L, C_H to B) the protection circuit recognizes this fault condition and the transmitter output stages are disabled with a delay of max. 10 ms to prevent destruction of the IC and high consumption of supply current I_S . If $V_{C_L} > V_{C_L\ max}$ the transmitter output stages would be disabled immediately.

Pin ASC makes it possible to select two different modes of operation: high speed (≤ 1 Mbaud) and low speed (≤ 250 kbaud).

The ASC pin is tied to GND for normal operation at ≤ 1 Mbaud. For slower speed operation at ≤ 250 kbaud the rise and fall slope of the bus output can be decreased to reduce EMI by connecting the ASC pin to V_S .

Table 6. Functional table

TXO	C_H	C_L	Bus state	RXO
L	H	L	Dominant	L
H or Floating	Floating $V_S/2$	Floating $V_S/2$	Recessive	H

Figure 3. Typical application

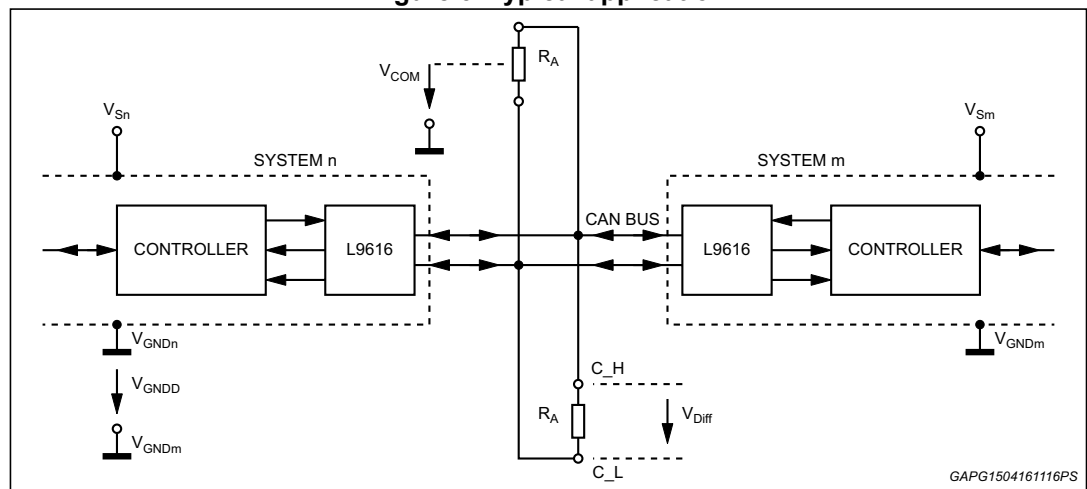

GAPG1504161116PS

Figure 4. Timing diagram

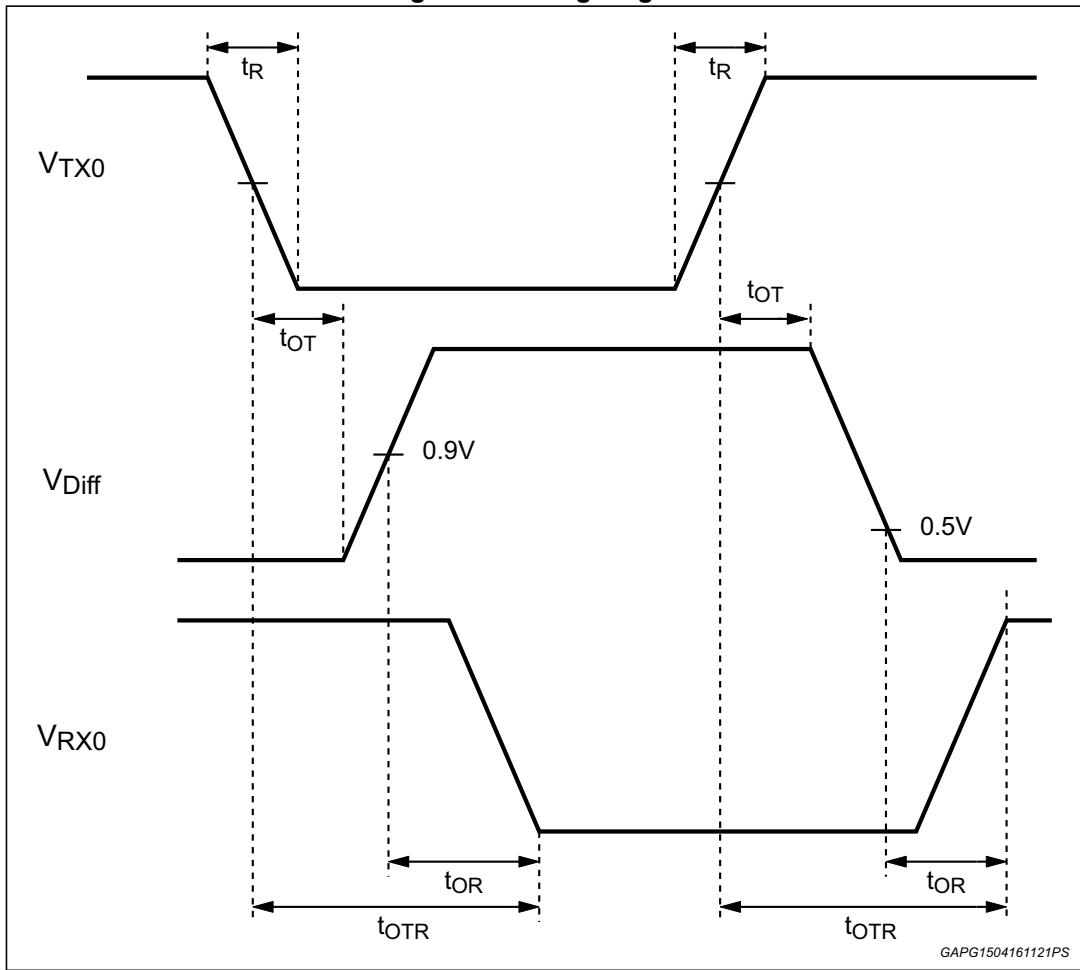

Figure 5. EMC performance (receiver)

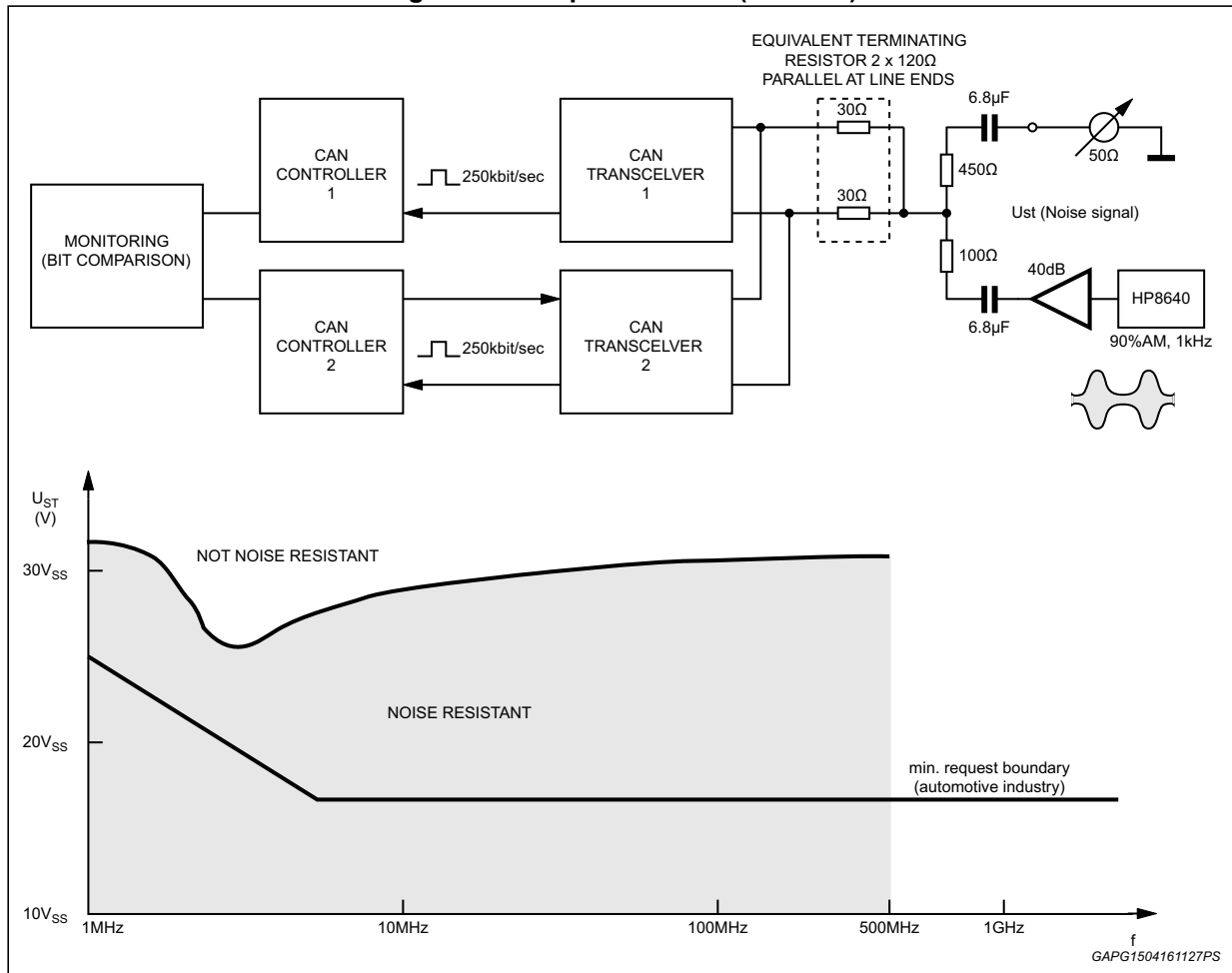

Figure 6. EMC performance (transmitter)

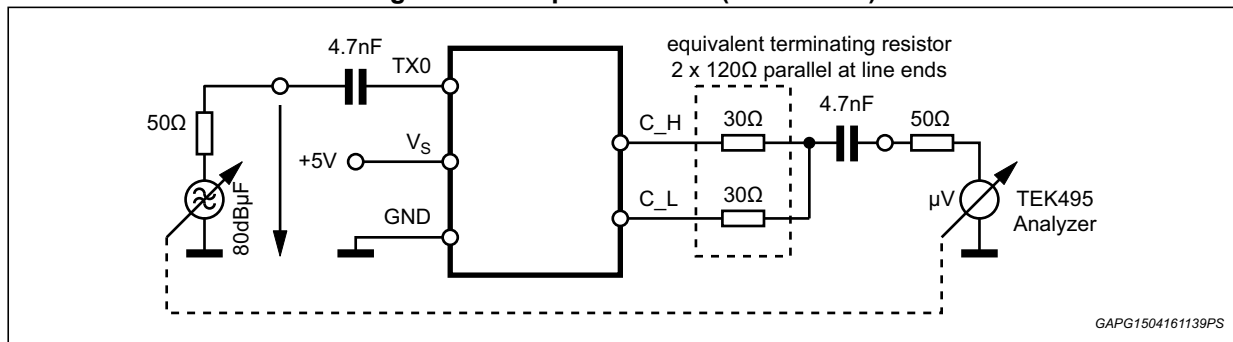

Figure 7. Transceiver without EMC reducing measures (transceiver)

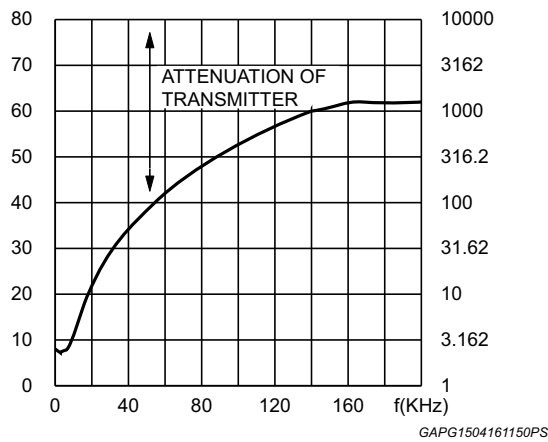

Figure 8. Transceiver with EMC reducing measures (transceiver)

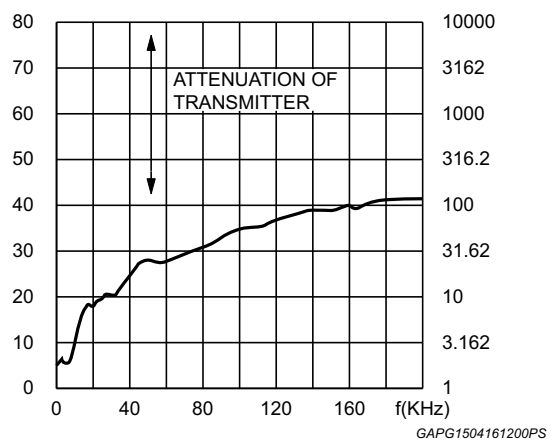

Figure 9. EMC performance (transceiver sending)

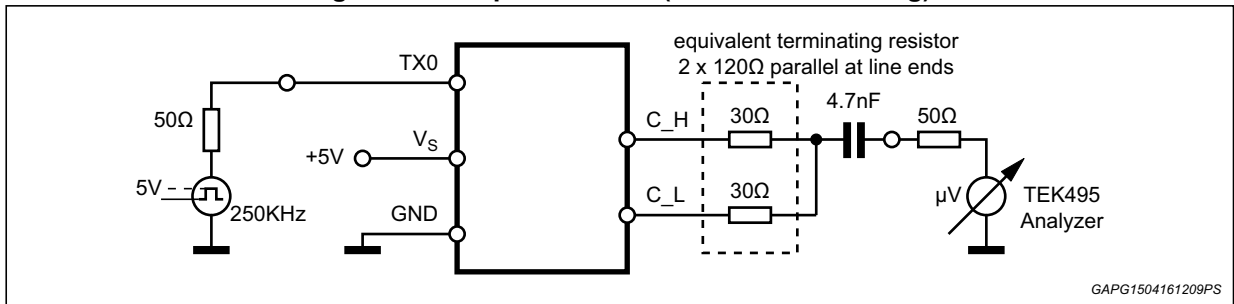

Figure 10. Transceiver without EMC reducing measures (transceiver)

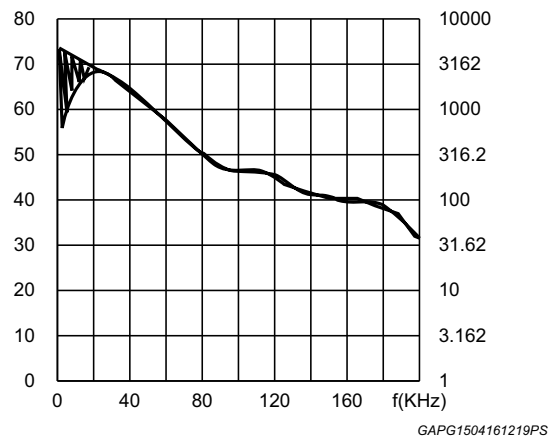
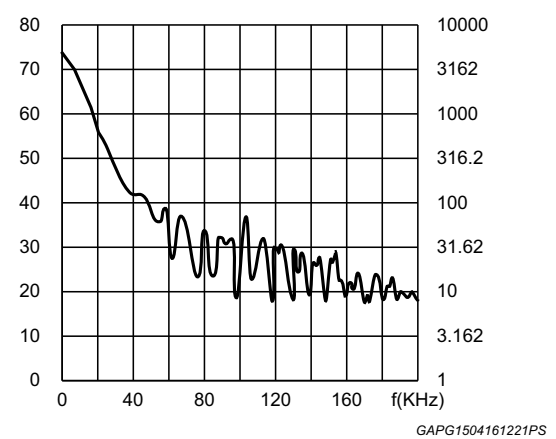

Figure 11. Transceiver with EMC reducing measures (transceiver)



5 Package information

In order to meet environmental requirements, ST offers these devices in different grades of ECOPACK[®] packages, depending on their level of environmental compliance. ECOPACK[®] specifications, grade definitions and product status are available at: www.st.com. ECOPACK[®] is an ST trademark.

5.1 SO-8 package information

Figure 12. SO-8 package outline

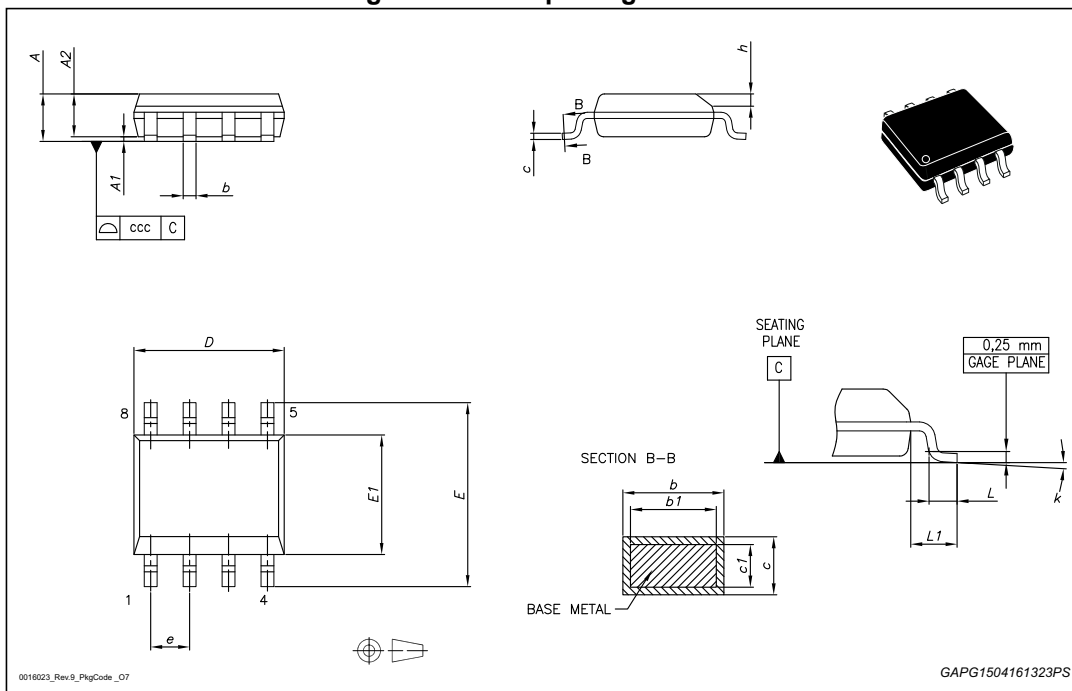

Table 7. SO-8 package mechanical data

Ref	Dimensions					
	Millimeters			Inches ⁽¹⁾		
	Min.	Typ.	Max.	Min.	Typ.	Max.
A	-	-	1.75	-	-	0.0689
A1	0.1	-	0.25	0.0039	-	0.0098
A2	1.25	-	-	0.0492	-	-
b	0.28	-	0.48	0.0110	-	0.0189
c	0.17	-	0.23	0.0067	-	0.0091
D ⁽²⁾	4.8	4.9	5	0.1890	0.1929	0.1969
E	5.8	6	6.2	0.2283	0.2362	0.2441
E1 ⁽³⁾	3.8	3.9	4	0.1496	0.1535	0.1575
e	-	1.27	-	-	0.0500	-
h	0.25	-	0.5	0.0098	-	0.0197
L	0.4	-	1.27	0.0157	-	0.0500
L1	-	1.04	-	-	0.0409	-
k	-	-	8	-	-	0.3150
ccc	-	-	0.1	-	-	0.0039

1. Values in inches are converted from mm and rounded to 4 decimal digits.
2. Dimension "D" does not include mold flash, protrusions or gate burrs.
Mold flash, protrusions or gate burrs shall not exceed 0.15mm in total (both side).
3. Dimension "E1" does not include inter-lead flash or protrusions.
Inter lead flash or protrusions shall not exceed 0.25mm per side.

6 Revision history

Table 8. Document revision history

Date	Revision	Changes
11-Jun-2008	1	Initial release.
27-Sep-2013	2	Updated disclaimer.
14-Jun-2016	3	Modified title in cover page. Added bullet "AEC-Q100 qualified" in cover page. Updated order codes in <i>Table 1: Device summary on page 1</i> . Updated <i>Section 5: Package information on page 14</i> .

IMPORTANT NOTICE – PLEASE READ CAREFULLY

STMicroelectronics NV and its subsidiaries (“ST”) reserve the right to make changes, corrections, enhancements, modifications, and improvements to ST products and/or to this document at any time without notice. Purchasers should obtain the latest relevant information on ST products before placing orders. ST products are sold pursuant to ST’s terms and conditions of sale in place at the time of order acknowledgement.

Purchasers are solely responsible for the choice, selection, and use of ST products and ST assumes no liability for application assistance or the design of Purchasers’ products.

No license, express or implied, to any intellectual property right is granted by ST herein.

Resale of ST products with provisions different from the information set forth herein shall void any warranty granted by ST for such product.

ST and the ST logo are trademarks of ST. All other product or service names are the property of their respective owners.

Information in this document supersedes and replaces information previously supplied in any prior versions of this document.

© 2016 STMicroelectronics – All rights reserved