

### DUAL PRE-AMPLIFIER

- Dual pre amplifier for car or home stereo use.
- High voltage gain :  $G_{VO}=100\text{dB(Typ.)}$  at  $f=1\text{kHz}$ .
- Excellent channel separation and high ripple rejection.
  - :  $CH_{\text{sep}}=65\text{dB(Typ.)}$
  - ( $f=10\text{kHz}$ ,  $R_g=2.2\text{k}\Omega$ ,  $V_{\text{out}}=0\text{dBm}$ )
  - :  $R.R=50\text{dB(Typ.)}$
- Low noise :  $V_{NI}=1.0\mu\text{V}_{\text{rms}}(\text{Typ.})$   
at  $R_g=2.2\text{k}\Omega$ ,  $B_w=20\text{Hz}\sim 20\text{kHz}$ .
- Wide operating supply voltage range.
  - :  $V_{CC}=6\sim 16\text{V}$  ( $T_a=25^\circ\text{C}$ )

### MAXIMUM RATINGS ( $T_a=25^\circ\text{C}$ )

CHARACTERISTIC	SYMBOL	RATING	UNIT
Supply Voltage	$V_{CC}$	16	V
Power Dissipation (Note)	KIA6225P	600	mW
	KIA6225S	700	
Operating Temperature	$T_{\text{opr}}$	$-30\sim 85$	$^\circ\text{C}$
Storage temperature	$T_{\text{stg}}$	$-55\sim 150$	$^\circ\text{C}$

Note: Derated above  $T_a=25^\circ\text{C}$  in the proportion of  $5.6\text{mW}/^\circ\text{C}^2$  for KIA6225S, and of  $4.8\text{mW}/^\circ\text{C}^2$  for KIA6225P.

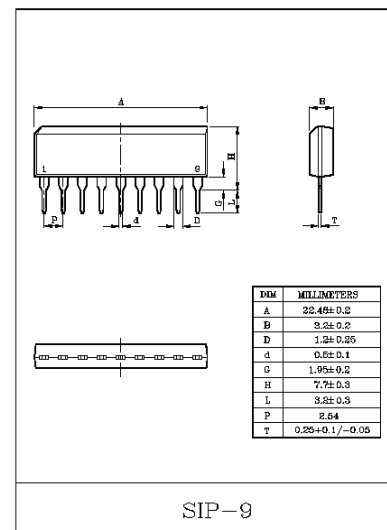
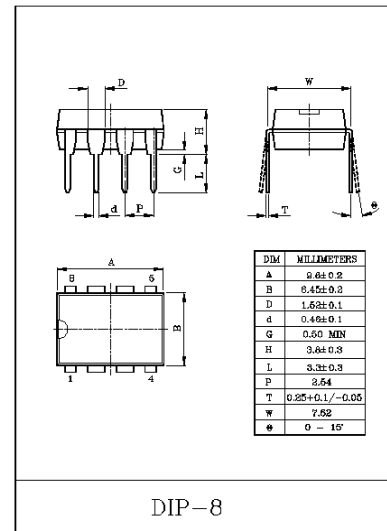

### ELECTRICAL CHARACTERISTICS

(Unless otherwise specified,  $V_{CC}=6\text{V}$ ,  $f=1\text{kHz}$ ,  $R_g=600\Omega$ ,  $R_L=10\text{k}\Omega$ ,  $T_a=25^\circ\text{C}$ )

CHARACTERISTIC	SYMBOL	TEST CIRCUIT	TEST CONDITION	MIN.	TYP.	MAX.	UNIT
Supply Current	$I_{CC}$	-	$V_{IN}=0$	-	3	6	mA
Voltage Gain	$G_{VO}$	-	$V_{OUT}=0\text{dBm}$	75	100	-	dB
	$G_V$	-	$V_{OUT}=0\text{dBm}$	38.5	41.5	44.5	
Maximum Output Voltage	$V_{OM}$	-	THD=1%	1.0	1.8	-	$V_{\text{rms}}$
Equivalent Input Noise Voltage	$V_{NI}$	-	$R_g=2.2\text{k}\Omega$ , $BPF=20\text{Hz}\sim 20\text{kHz}$	-	1.0	1.7	$\mu\text{V}_{\text{rms}}$
Input Resistance	$R_{IN}$	-	-	50	150	-	$\text{k}\Omega$
Channel Separation	$CH_{\text{sep}}$	-	$f=10\text{kHz}$ , $V_{OUT}=0\text{dBm}$	-	65	-	dB
Ripple Rejection	R.R	-	$f=100\text{Hz}$ , $R_g=2.2\text{k}\Omega$	-	50	-	dB
Total Harmonic Distortion	THD	-	$V_{OUT}=0\text{dBm}$	-	0.04	0.25	%

# KIA6225P/S

## TEST CIRCUIT

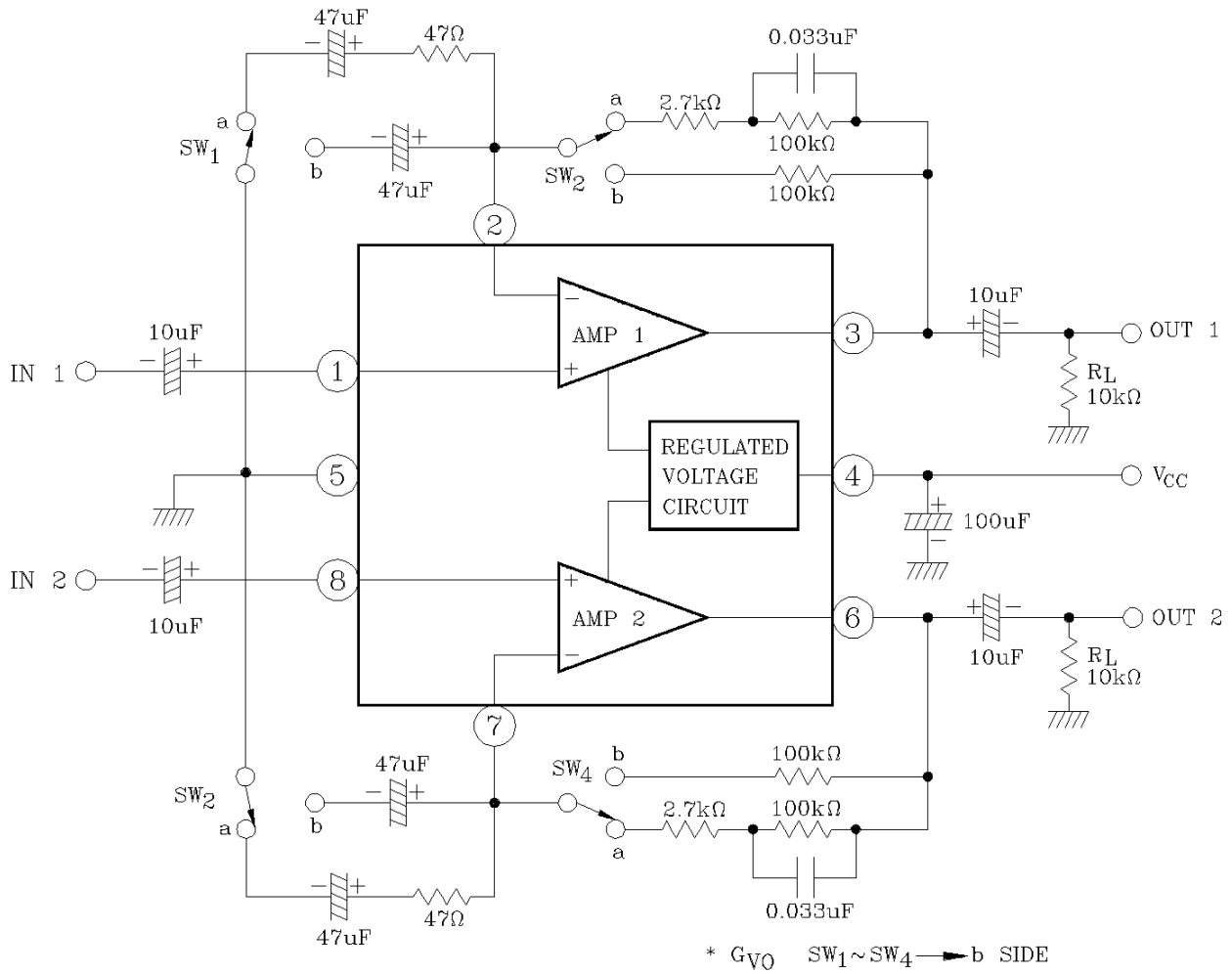

# KIA6225P/S

## APPLICATION CIRCUIT

NAB EQ

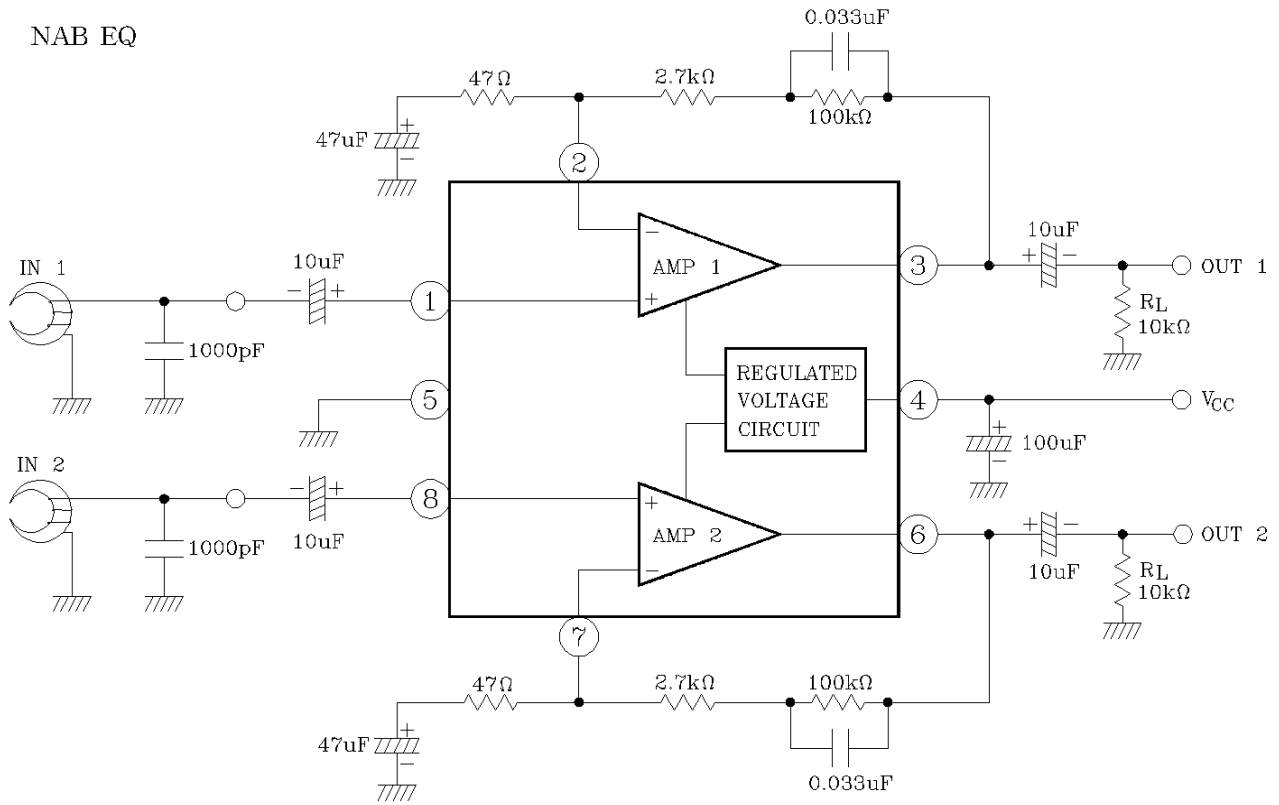

# KIA6225P/S

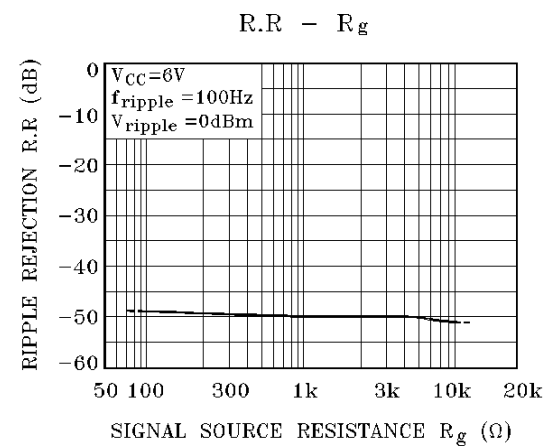
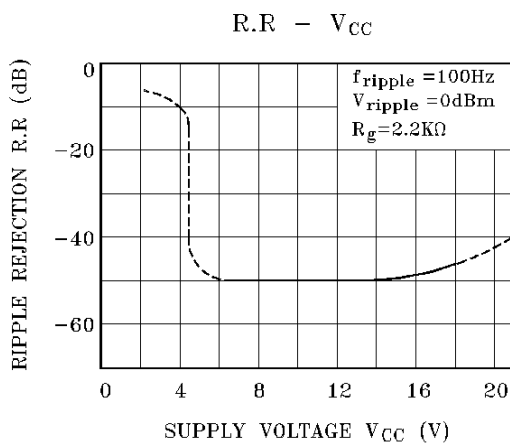
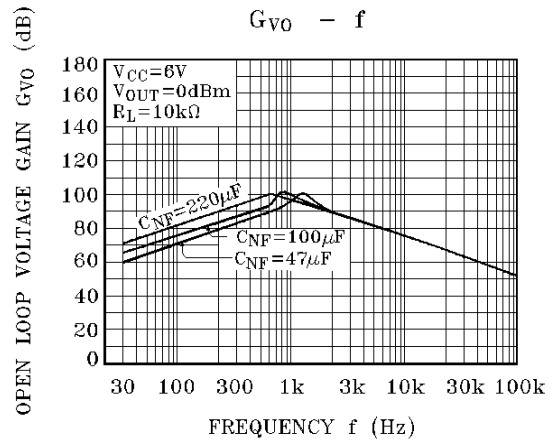
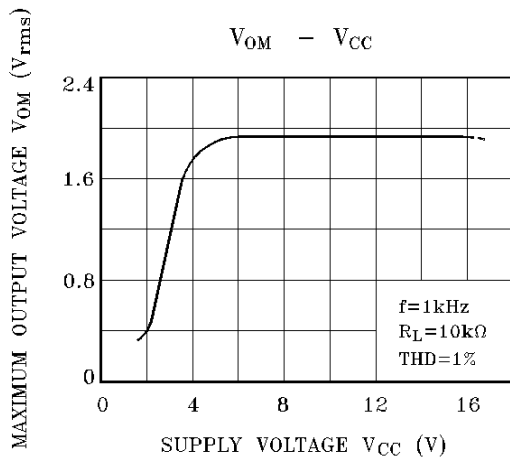
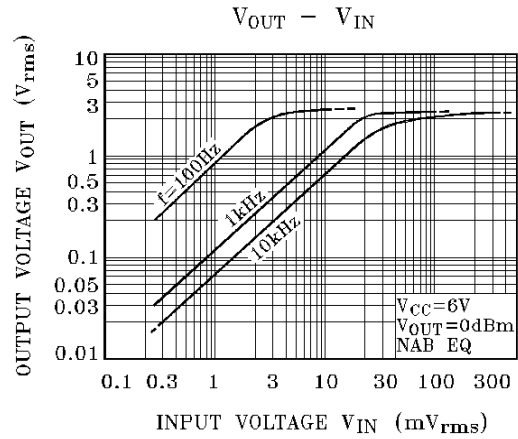
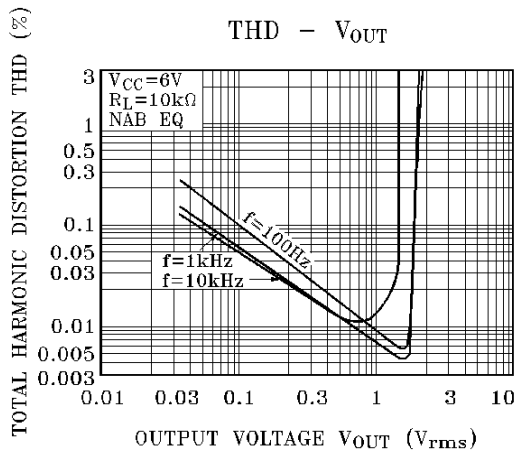

# KIA6225P/S

