

**STROBED HEX INVERTER/BUFFER**

- 2 TTL-LOAD OUTPUT DRIVE CAPABILITY
- 3-STATE OUTPUTS
- COMMON OUTPUT-DISABLE CONTROL
- INHIBIT CONTROL
- QUIESCENT CURRENT SPECIFIED TO 20V FOR HCC DEVICE
- 5V, 10V, AND 15V PARAMETRIC RATINGS
- INPUT CURRENT OF 100nA AT 18V AND 25°C FOR HCC DEVICE
- 100% TESTED FOR QUIESCENT CURRENT
- MEETS ALL REQUIREMENTS OF JEDEC TENTATIVE STANDARD N°. 13A, "STANDARD SPECIFICATIONS FOR DESCRIPTION OF "B" SERIES CMOS DEVICES"

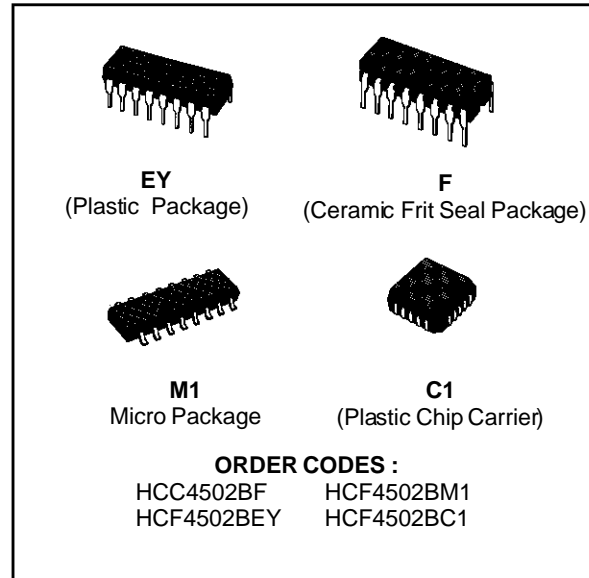

**DESCRIPTION**

The **HCC4502B** (extended temperature range) and **HCF4502B** (intermediate temperature range) are monolithic integrated circuit, available in 16-lead dual in-line plastic or ceramic package and plastic micro package. The **HCC/HCF 4502B** consists of six inverter-buffers with 3-state outputs. A logic "1" on the OUTPUT DISABLE input produces a high-impedance state in all six outputs. This feature permits common bussing of the outputs, thus simplifying system design. A logic "1" on the INHIBIT input switches all six outputs to logic "0" if the OUTPUT DISABLE input is a logic "0". This device is capable of driving two standard TTL loads, which is equivalent to six times the JEDEC "B" series I<sub>OL</sub> standard.

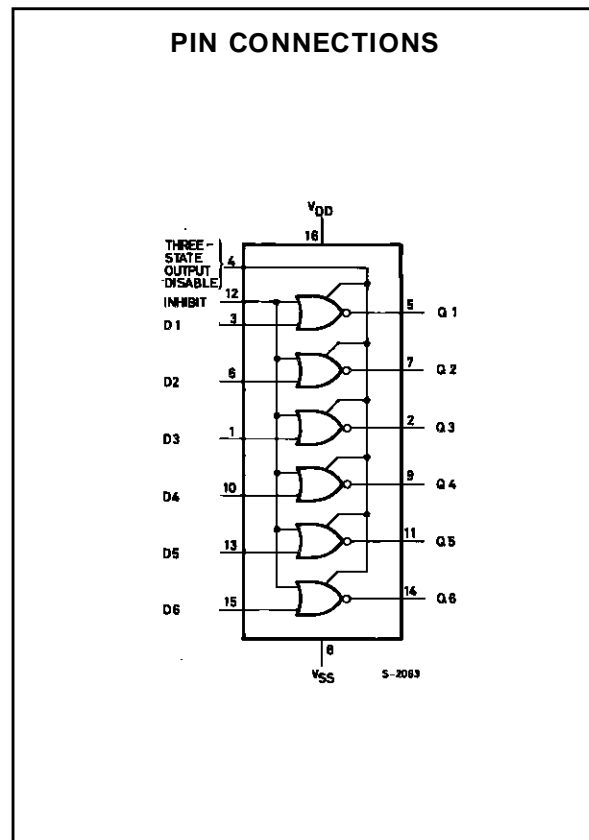

## HCC/HCF4502B

### ABSOLUTE MAXIMUM RATINGS

Symbol	Parameter	Value	Unit
$V_{DD}^*$	Supply Voltage : <b>HCC</b> Types <b>HCF</b> Types	- 0.5 to + 20	V
		- 0.5 to + 18	V
$V_i$	Input Voltage	- 0.5 to $V_{DD} + 0.5$	V
$I_i$	DC Input Current (any one input)	$\pm 10$	mA
$P_{tot}$	Total Power Dissipation (per package) Dissipation per Output Transistor for $T_{op}$ = Full Package-temperature Range	200	mW
		100	mW
$T_{op}$	Operating Temperature : <b>HCC</b> Types <b>HCF</b> Types	- 55 to + 125	°C
		- 40 to + 85	°C
$T_{stg}$	Storage Temperature	- 65 to + 150	°C

Stresses above those listed under "Absolute Maximum Ratings" may cause permanent damage to the device. This is a stress rating only and functional operation of the device at these or any other conditions above those indicated in the operational sections of this specification is not implied. Exposure to absolute maximum rating conditions for external periods may affect device reliability.

\* All voltage values are referred to  $V_{SS}$  pin voltage.

### RECOMMENDED OPERATING CONDITIONS

Symbol	Parameter	Value	Unit
$V_{DD}$	Supply Voltage : <b>HCC</b> Types <b>HCF</b> Types	3 to + 18	V
		3 to + 15	V
$V_i$	Input Voltage	0 to $V_{DD}$	V
$T_{op}$	Operating Temperature : <b>HCC</b> Types <b>HCF</b> Types	- 55 to + 125	°C
		- 40 to + 85	°C

### TRUTH TABLE

Disable	Inhibit	Dn	Qn
0	0	0	1
0	0	1	0
0	1	X	0
1	X	X	Z

X = don't care

Z = high impedance

Logic 1 = high

Logic 0 = low

## STATIC ELECTRICAL CHARACTERISTICS (over recommended operating conditions)

Symbol	Parameter		Test Conditions				Value						Unit	
			V <sub>I</sub> (V)	V <sub>O</sub> (V)	I <sub>O</sub>   ( $\mu$ A)	V <sub>DD</sub> (V)	T <sub>Low</sub> *		25°C			T <sub>High</sub> *		
							Min.	Max.	Min.	Typ.	Max.	Min.		Max.
I <sub>L</sub>	Quiescent Current	HCC Types	0/ 5			5		1		0.02	1		30	
			0/10			10		2		0.02	2		60	
			0/15			15		4		0.02	4		120	
			0/20			20		20		0.04	20		600	
		HCF Types	0/ 5			5		4		0.02	4		30	
			0/10			10		8		0.02	8		60	
V <sub>OH</sub>	Output High Voltage		0/ 5		< 1	5	4.95		4.95			4.95	V	
			0/10		< 1	10	9.95		9.95			9.95		
			0/15		< 1	15	14.95		14.95			14.95		
V <sub>OL</sub>	Output Low Voltage		5/0		< 1	5		0.05			0.05	0.05	V	
			10/0		< 1	10		0.05			0.05	0.05		
			15/0		< 1	15		0.05			0.05	0.05		
V <sub>IH</sub>	Input High Voltage			0.5/4.5	< 1	5	3.5		3.5			3.5	V	
				1/9	< 1	10	7		7			7		
				1.5/13.5	< 1	15	11		11			11		
V <sub>IL</sub>	Input Low Voltage			4.5/0.5	< 1	5		1.5			1.5	1.5	V	
				9/1	< 1	10		3			3	3		
				13.5/1.5	< 1	15		4			4	4		
I <sub>OH</sub>	Output Drive Current	HCC Types	0/ 5	2.5		5	- 2		- 1.6	- 3.2		-1.15	mA	
			0/ 5	4.6		5	-0.64		-0.51	- 1		-0.36		
			0/10	9.5		10	- 1.6		- 1.3	- 2.6		- 0.9		
			0/15	13.5		15	- 4.2		- 3.4	- 6.8		- 2.4		
		HCF Types	0/ 5	2.5		5	-1.53		-1.36	- 3.2		- 1.1		
			0/ 5	4.6		5	-0.52		-0.44	- 1		-0.36		
I <sub>OL</sub>	Output Sink Current	HCC Types	0/ 5	0.4		5	3.84		3.06	6		2.10	mA	
			0/10	0.5		10	9.6		7.8	15.6		5.4		
			0/15	1.5		15	25.2		20.4	40.8		14.4		
		HCF Types	0/ 5	0.4		5	3.11		2.6	6		2.10		
			0/10	0.5		10	7.05		6.63	15.6		5.61		
			0/15	1.5		15	20.4		17.3	40.8		14.2		
I <sub>IH</sub> , I <sub>IL</sub>	Input Leakage Current	HCC Types	0/18	Any Input		18		$\pm$ 0.1		$\pm$ 10 <sup>-5</sup>	$\pm$ 0.1		$\pm$ 1	
		HCF Types	0/15											15
I <sub>OH</sub> , I <sub>OL</sub>	3-state Output	HCC Types	0/18			18		$\pm$ 0.4		$\pm$ 10 <sup>-4</sup>	$\pm$ 0.4		$\pm$ 12	
		HCF Types	0/15			15		$\pm$ 1.0		$\pm$ 10 <sup>-4</sup>	$\pm$ 1.0		$\pm$ 7.5	
C <sub>I</sub>	Input Capacitance			Any Input					5	7.5			pF	

\* T<sub>Low</sub>= - 55°C for HCC device : - 40°C for HCF device.\* T<sub>High</sub>= + 125°C for HCC device : + 85°C for HCF device.The Noise Margin for both "1" and "0" level is : 1V min. with V<sub>DD</sub> = 5V, 2V min. with V<sub>DD</sub> = 10V, 2.5V min. with V<sub>DD</sub> = 15V.

# HCC/HCF4502B

**DYNAMIC ELECTRICAL CHARACTERISTICS** ( $T_{amb} = 25\text{ }^{\circ}\text{C}$ ,  $C_L = 50\text{ pF}$ ,  $R_L = 200\text{ k}\Omega$   
 typical temperature coefficient for all  $V_{DD}$  values is  $0.3\text{ }^{\circ}\text{C}$ , all input rise and fall times =  $20\text{ ns}$ )

Symbol	Parameter	Test Conditions		Value			Unit
			$V_{DD}$ (V)	Min.	Typ.	Max.	
$t_{PHL}$	Data or Inhibit Delay Time		5		135	270	ns
			10		60	120	
			15		40	80	
$t_{PLH}$	Data or Inhibit Delay Time		5		190	380	ns
			10		90	180	
			15		65	30	
$t_{PHZ}$	Disable Delay Time (output high to high impedance)		5		60	120	ns
			10		40	80	
			15		30	60	
$t_{PZH}$	Disable Delay Time (high impedance to output high)		5		110	220	ns
			10		50	100	
			15		40	80	
$t_{PLZ}$	Disable Delay Time (output low to high impedance)		5		125	250	ns
			10		65	130	
			15		55	110	
$t_{PZL}$	Disable Delay Time (high impedance to output low)		5		125	250	ns
			10		55	110	
			15		40	80	
$t_{TLH}$	Transition Time		5		100	200	ns
			10		50	100	
			15		40	80	
$t_{THL}$	Transition Time		5		60	120	ns
			10		30	60	
			15		20	40	

Minimum Output High (source) Current Characteristics.

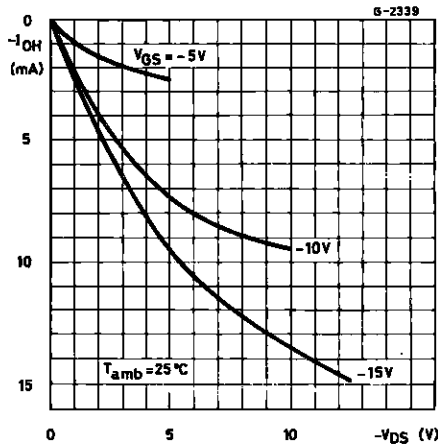

Typical Output Low (sink) Current.

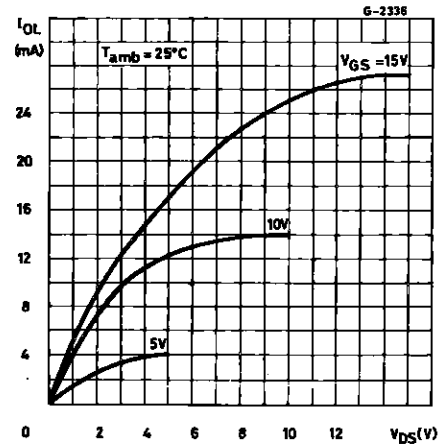

Minimum Output Low (sink) Current Characteristics.

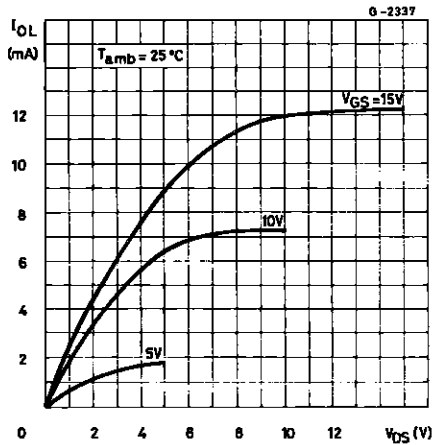

Typical Transition Time vs. Load Capacitance.

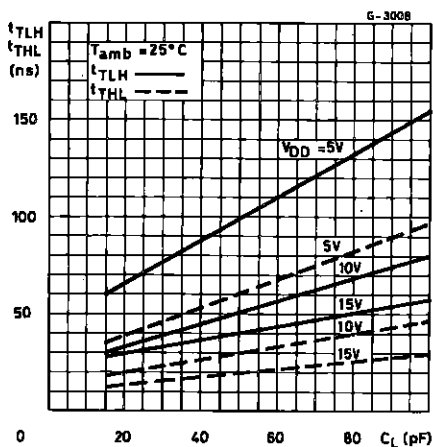

Typical Output High (source) Current Characteristics.

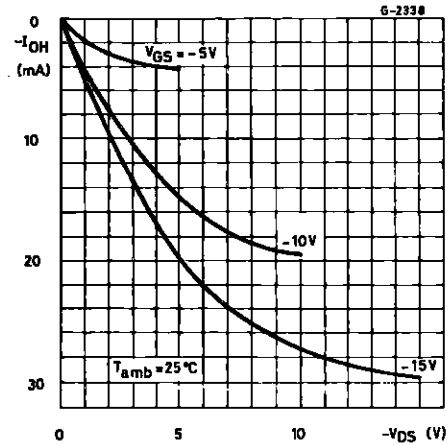

Typical Propagation Delay Time vs. Load Capacitance.

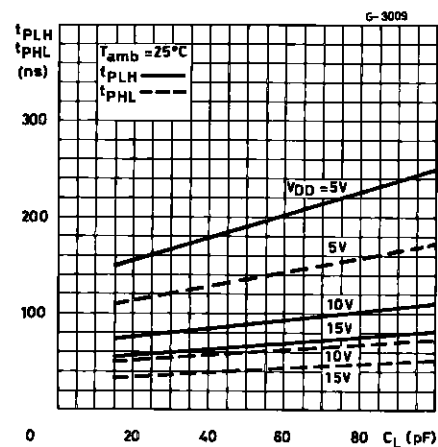

TEST CIRCUIT

Quiescent Device Current

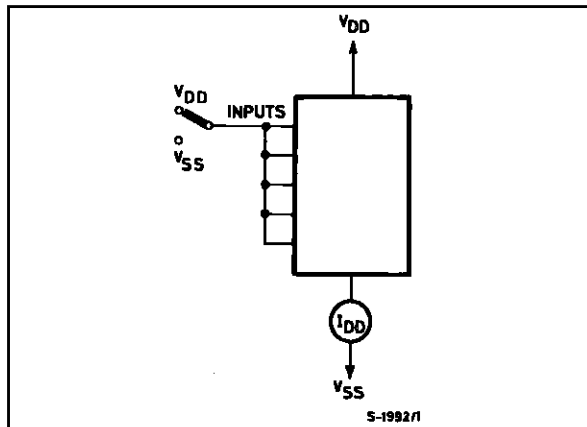

Input Voltage

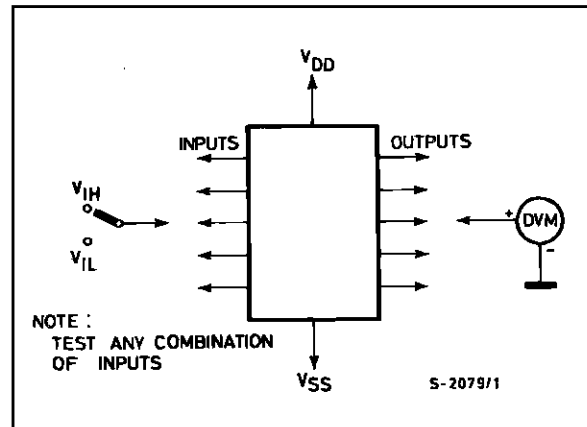

# HCC/HCF4502B

## TEST CIRCUIT (continued)

Input Leakage Current.

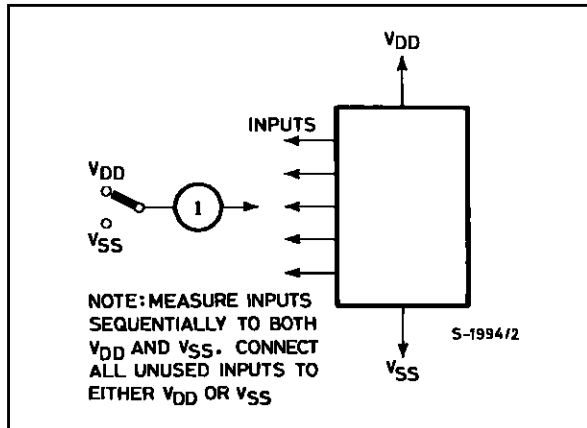

## TEST CIRCUIT AND WAVEFORMS

Disable Delay Time.

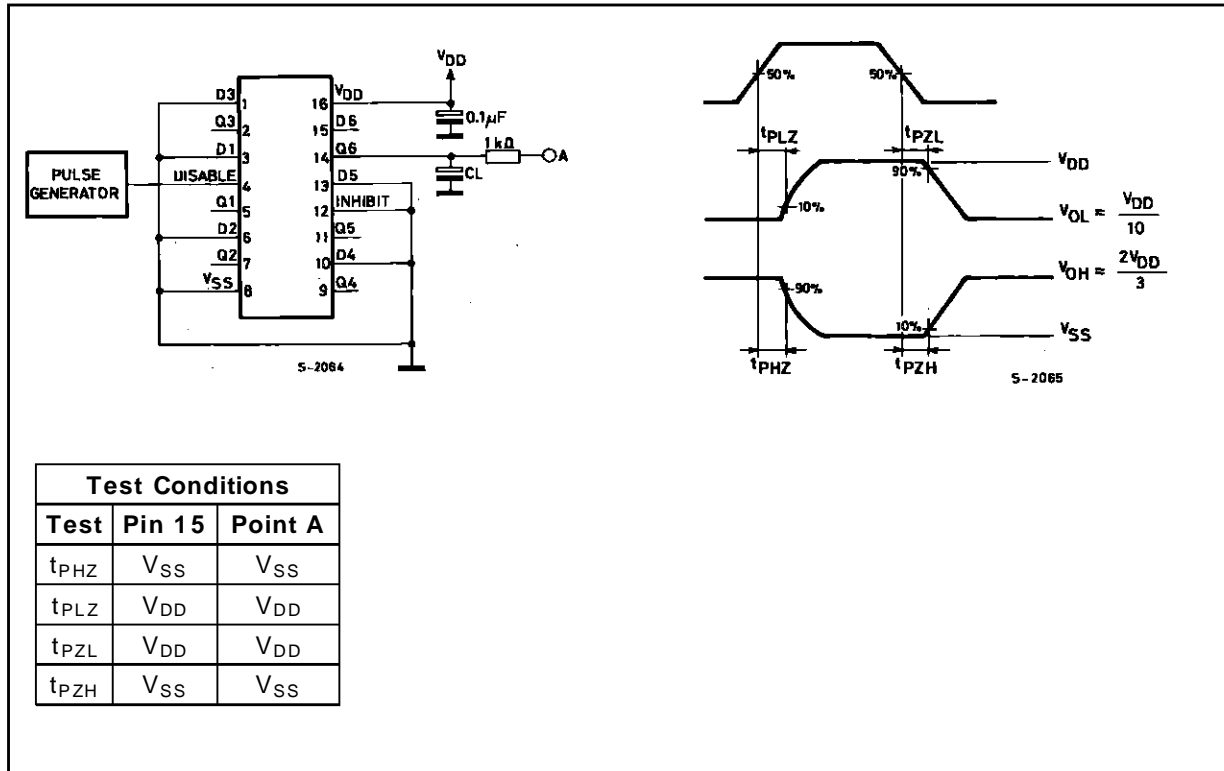

## Plastic DIP16 (0.25) MECHANICAL DATA

DIM.	mm			inch		
	MIN.	TYP.	MAX.	MIN.	TYP.	MAX.
a1	0.51			0.020		
B	0.77		1.65	0.030		0.065
b		0.5			0.020	
b1		0.25			0.010	
D			20			0.787
E		8.5			0.335	
e		2.54			0.100	
e3		17.78			0.700	
F			7.1			0.280
I			5.1			0.201
L		3.3			0.130	
Z			1.27			0.050



P001C

Ceramic DIP16/1 MECHANICAL DATA

DIM.	mm			inch		
	MIN.	TYP.	MAX.	MIN.	TYP.	MAX.
A			20			0.787
B			7			0.276
D		3.3			0.130	
E	0.38			0.015		
e3		17.78			0.700	
F	2.29		2.79	0.090		0.110
G	0.4		0.55	0.016		0.022
H	1.17		1.52	0.046		0.060
L	0.22		0.31	0.009		0.012
M	0.51		1.27	0.020		0.050
N			10.3			0.406
P	7.8		8.05	0.307		0.317
Q			5.08			0.200

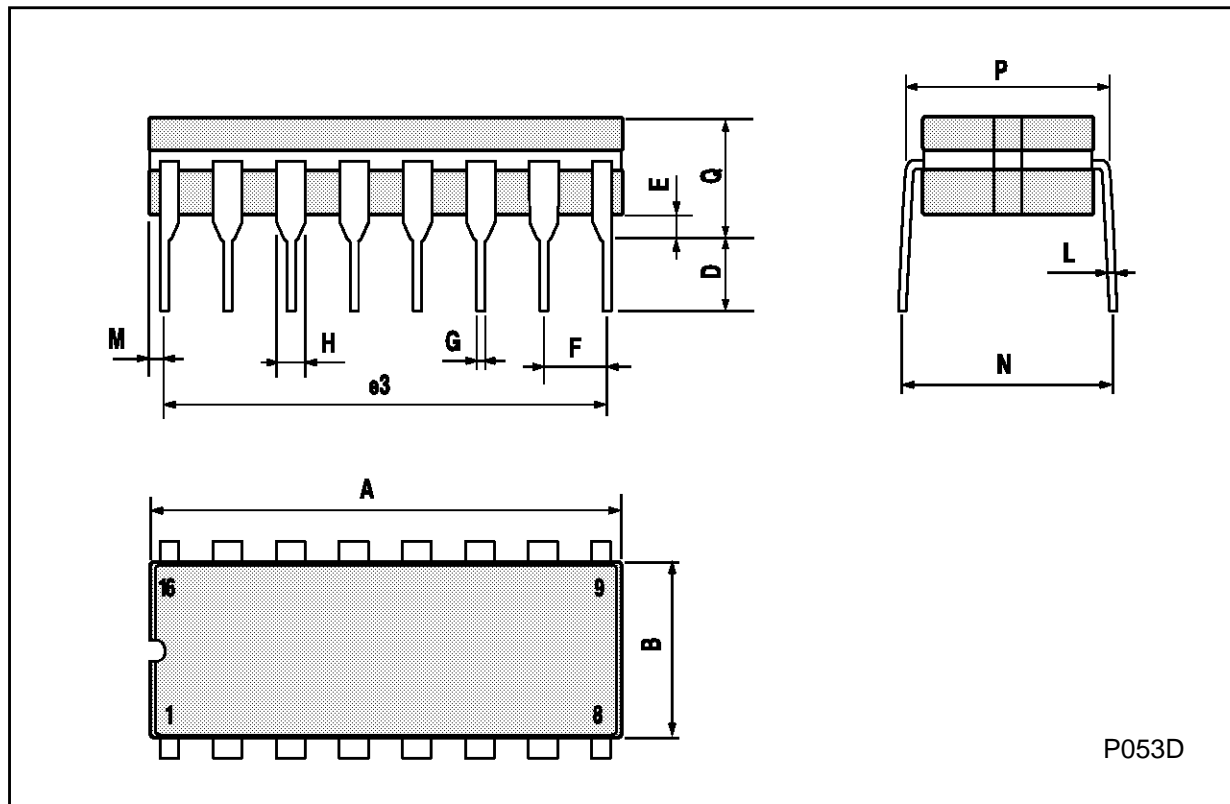



## SO16 (Narrow) MECHANICAL DATA

DIM.	mm			inch		
	MIN.	TYP.	MAX.	MIN.	TYP.	MAX.
A			1.75			0.068
a1	0.1		0.2	0.004		0.007
a2			1.65			0.064
b	0.35		0.46	0.013		0.018
b1	0.19		0.25	0.007		0.010
C		0.5			0.019	
c1	45° (typ.)					
D	9.8		10	0.385		0.393
E	5.8		6.2	0.228		0.244
e		1.27			0.050	
e3		8.89			0.350	
F	3.8		4.0	0.149		0.157
G	4.6		5.3	0.181		0.208
L	0.5		1.27	0.019		0.050
M			0.62			0.024
S	8° (max.)					



P013H

**PLCC20 MECHANICAL DATA**

DIM.	mm			inch		
	MIN.	TYP.	MAX.	MIN.	TYP.	MAX.
A	9.78		10.03	0.385		0.395
B	8.89		9.04	0.350		0.356
D	4.2		4.57	0.165		0.180
d1		2.54			0.100	
d2		0.56			0.022	
E	7.37		8.38	0.290		0.330
e		1.27			0.050	
e3		5.08			0.200	
F		0.38			0.015	
G			0.101			0.004
M		1.27			0.050	
M1		1.14			0.045	



Information furnished is believed to be accurate and reliable. However, SGS-THOMSON Microelectronics assumes no responsibility for the consequences of use of such information nor for any infringement of patents or other rights of third parties which may result from its use. No license is granted by implication or otherwise under any patent or patent rights of SGS-THOMSON Microelectronics. Specifications mentioned in this publication are subject to change without notice. This publication supersedes and replaces all information previously supplied. SGS-THOMSON Microelectronics products are not authorized for use as critical components in life support devices or systems without express written approval of SGS-THOMSON Microelectronics.

© 1994 SGS-THOMSON Microelectronics - All Rights Reserved

SGS-THOMSON Microelectronics GROUP OF COMPANIES

Australia - Brazil - France - Germany - Hong Kong - Italy - Japan - Korea - Malaysia - Malta - Morocco - The Netherlands -  
Singapore - Spain - Sweden - Switzerland - Taiwan - Thailand - United Kingdom - U.S.A