



# HCF40104B

## 4-BIT BIDIRECTIONAL UNIVERSAL SHIFT REGISTER

- MEDIUM SPEED OPERATION :  
12 MHz (Typ.) at 10V
- FULLY STATIC OPERATION
- SYNCHRONOUS PARALLEL OR SERIAL OPERATION
- THREE-STATE OUTPUTS
- STANDARDIZED SYMMETRICAL OUTPUT CHARACTERISTICS
- QUIESCENT CURRENT SPECIF. UP TO 20V
- 5V, 10V AND 15V PARAMETRIC RATINGS
- INPUT LEAKAGE CURRENT  
 $I_1 = 100\text{nA (MAX) AT } V_{DD} = 18\text{V } T_A = 25^\circ\text{C}$
- 100% TESTED FOR QUIESCENT CURRENT
- MEETS ALL REQUIREMENTS OF JEDEC JESD13B "STANDARD SPECIFICATIONS FOR DESCRIPTION OF B SERIES CMOS DEVICES"

### DESCRIPTION

HCF40104B is a monolithic integrated circuit fabricated in Metal Oxide Semiconductor technology available in DIP packages.

HCF40104B is a universal shift register featuring parallel inputs, parallel outputs, SHIFT RIGHT and SHIFT LEFT serial inputs, and a high-impedance third output state allowing the device to be used in bus-organized systems. In the parallel-load mode (SO and S1 are high), data is loaded into the

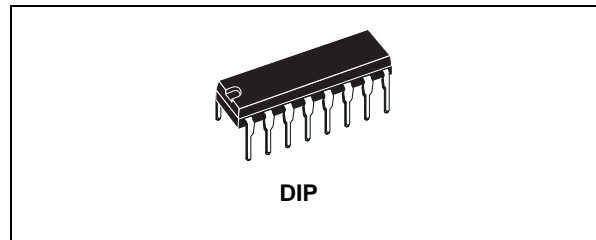

### ORDER CODES

PACKAGE	TUBE	T & R
DIP	HCF40104BEY	

associated flip-flop and appears at the output after the positive transition of the CLOCK input. During loading, serial data flow is inhibited. Shift-right and shift-left are synchronously accomplished on the positive clock edge with serial data entered at the SHIFT RIGHT and SHIFT LEFT serial inputs, respectively. Clearing the register is accomplished by setting both mode controls low and clocking the register. When the output enable input is low, all outputs assume the high impedance state.

### PIN CONNECTION

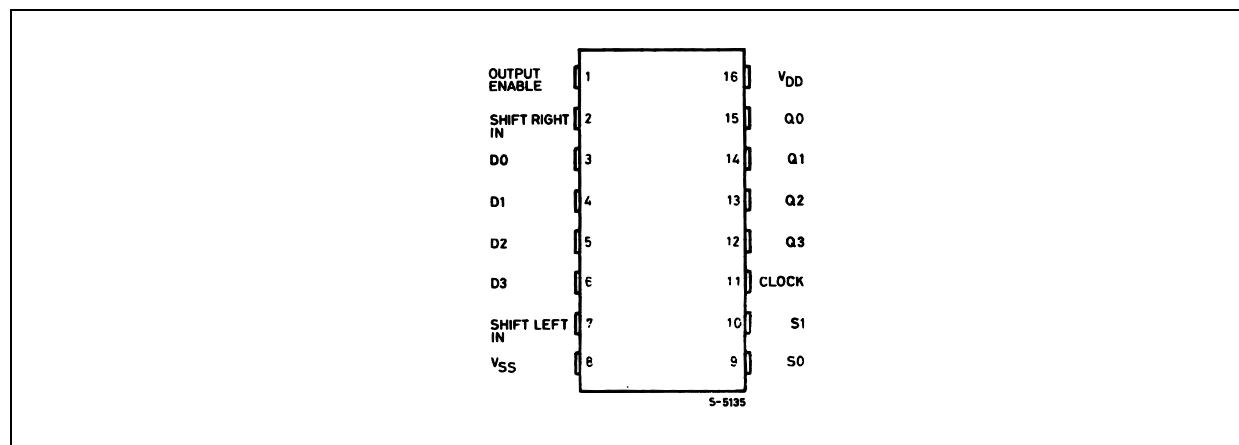

# HCF40104B

## IINPUT EQUIVALENT CIRCUIT

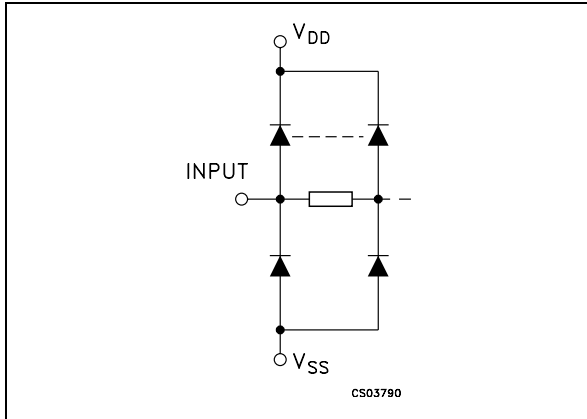

## PIN DESCRIPTION

PIN No	SYMBOL	NAME AND FUNCTION
1	OUTPUT ENABLE	Output Enable
3, 4, 5, 6	D0 to D3	Inputs
15, 14, 13, 12	Q0 to Q3	Outputs
2	Shift Right IN	Shift Right Input
7	Shift Left IN	Shift Left Input
11	CLOCK	Clock Input
9, 10	S0, S1	Input (High)
8	V <sub>SS</sub>	Negative Supply Voltage
16	V <sub>DD</sub>	Positive Supply Voltage

## FUNCTIONAL DIAGRAM

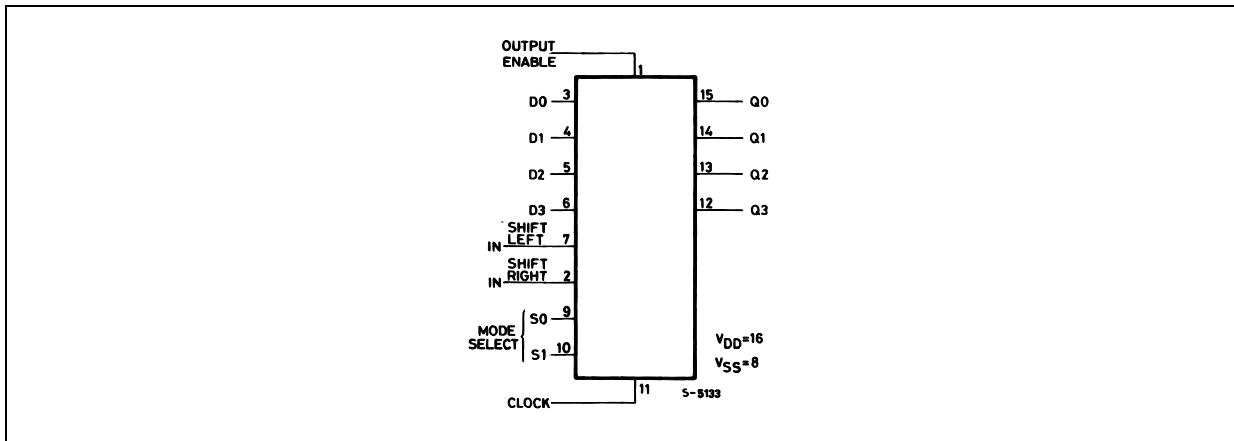

## TRUTH TABLE

CLOCK	MODE SELECT		OUTPUT ENABLE	ACTION
	S0	S1		
	L	L	H	RESET
	H	L	H	SHIFT RIGHT (Q0 toward Q3)
	L	H	H	SHIFT LEFT (Q3 toward Q0)
	H	H	H	PARALLEL LOAD
X	X	X	L	Operations occur as shown above, but outputs assume high impedance

X : Don't Care

LOGIC DIAGRAM

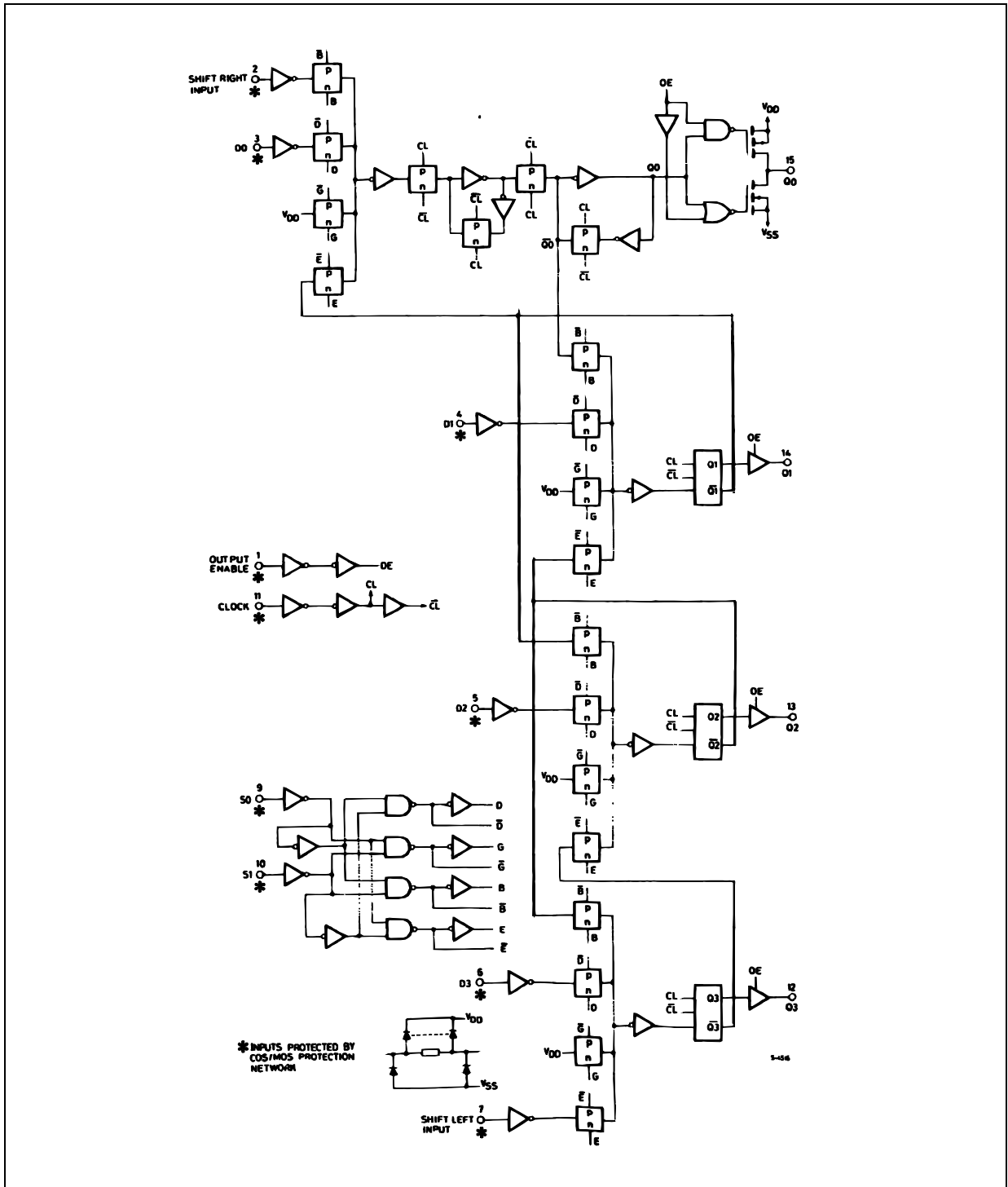

**ABSOLUTE MAXIMUM RATINGS**

Symbol	Parameter	Value	Unit
$V_{DD}$	Supply Voltage	-0.5 to +22	V
$V_I$	DC Input Voltage	-0.5 to $V_{DD} + 0.5$	V
$I_I$	DC Input Current	$\pm 10$	mA
$P_D$	Power Dissipation per Package	200	mW
	Power Dissipation per Output Transistor	100	mW
$T_{op}$	Operating Temperature	-55 to +125	°C
$T_{stg}$	Storage Temperature	-65 to +150	°C

Absolute Maximum Ratings are those values beyond which damage to the device may occur. Functional operation under these conditions is not implied.

All voltage values are referred to  $V_{SS}$  pin voltage.

**RECOMMENDED OPERATING CONDITIONS**

Symbol	Parameter	Value	Unit
$V_{DD}$	Supply Voltage	3 to 20	V
$V_I$	Input Voltage	0 to $V_{DD}$	V
$T_{op}$	Operating Temperature	-55 to 125	°C

## DC SPECIFICATIONS

Symbol	Parameter	Test Condition				Value						Unit	
		V <sub>I</sub> (V)	V <sub>O</sub> (V)	I <sub>OL</sub>   ( $\mu$ A)	V <sub>DD</sub> (V)	T <sub>A</sub> = 25°C			-40 to 85°C		-55 to 125°C		
						Min.	Typ.	Max.	Min.	Max.	Min.		Max.
I <sub>L</sub>	Quiescent Current	0/5			5		0.04	5		150		150	$\mu$ A
		0/10			10		0.04	10		300		300	
		0/15			15		0.04	20		600		600	
		0/20			20		0.08	100		3000		3000	
V <sub>OH</sub>	High Level Output Voltage	0/5		<1	5	4.95			4.95		4.95		V
		0/10		<1	10	9.95			9.95		9.95		
		0/15		<1	15	14.95			14.95		14.95		
V <sub>OL</sub>	Low Level Output Voltage	5/0		<1	5		0.05			0.05		0.05	V
		10/0		<1	10		0.05			0.05		0.05	
		15/0		<1	15		0.05			0.05		0.05	
V <sub>IH</sub>	High Level Input Voltage		0.5/4.5	<1	5	3.5			3.5		3.5		V
			1/9	<1	10	7			7		7		
			1.5/13.5	<1	15	11			11		11		
V <sub>IL</sub>	Low Level Input Voltage		4.5/0.5	<1	5			1.5		1.5		1.5	V
			9/1	<1	10			3		3		3	
			13.5/1.5	<1	15			4		4		4	
I <sub>OH</sub>	Output Drive Current	0/5	2.5	<1	5	-1.36	-3.2		-1.1		-1.1		mA
		0/5	4.6	<1	5	-0.44	-1		-0.36		-0.36		
		0/10	9.5	<1	10	-1.1	-2.6		-0.9		-0.9		
		0/15	13.5	<1	15	-3.0	-6.8		-2.4		-2.4		
I <sub>OL</sub>	Output Sink Current	0/5	0.4	<1	5	0.44	1		0.36		0.36		mA
		0/10	0.5	<1	10	1.1	2.6		0.9		0.9		
		0/15	1.5	<1	15	3.0	6.8		2.4		2.4		
I <sub>I</sub>	Input Leakage Current	0/18	Any Input		18		$\pm 10^{-5}$	$\pm 0.1$		$\pm 1$		$\pm 1$	$\mu$ A
C <sub>I</sub>	Input Capacitance		Any Input				5	7.5					pF

The Noise Margin for both "1" and "0" level is: 1V min. with V<sub>DD</sub>=5V, 2V min. with V<sub>DD</sub>=10V, 2.5V min. with V<sub>DD</sub>=15V

## HCF40104B

### DYNAMIC ELECTRICAL CHARACTERISTICS ( $T_{amb} = 25^{\circ}\text{C}$ , $C_L = 50\text{pF}$ , $R_L = 200\text{K}\Omega$ , $t_r = t_f = 20\text{ ns}$ )

Symbol	Parameter	Test Condition		Value (*)			Unit
		$V_{DD}$ (V)		Min.	Typ.	Max.	
$t_{PHL}$ , $t_{PLH}$	Propagation Delay Time Clock to Q	5			220	440	ns
		10			100	200	
		15			70	140	
$t_{PZH}$ , $t_{PZL}$ , $t_{PLZ}$	3-State Outputs High Impedance	5			80	160	ns
		10			35	70	
		15			25	50	
$t_{PHZ}$		5			45	90	ns
		10			25	50	
		15			20	40	
$t_{THL}$ , $t_{TLH}$	Transition Time	5			100	200	ns
		10			50	100	
		15			40	80	
$t_{setup}$	Setup Time D0, D3, SR, SL to Clock	5			80	100	ns
		10			35	70	
		15			20	50	
	SO, S1 to Clock	5			200	400	ns
		10			110	220	
		15			65	130	
$t_{hold}$	Hold Time D0, D3, SR, SL to Clock	5			-65	0	ns
		10			-25	0	
		15			-15	0	
	SO, S1 to Clock	5			-170	0	ns
		10			-95	0	
		15			-55	0	
$t_w$	Clock Pulse Width	5			90	180	ns
		10			40	180	
		15			25	50	
$f_{CL}$	Clock Input Frequency	5		3	6		MHz
		10		6	12		
		15		8	15		
$t_r$ , $t_f$	Clock Input Rise or Fall Time	5				1000	$\mu\text{s}$
		10				100	
		15				100	

TEST CIRCUIT

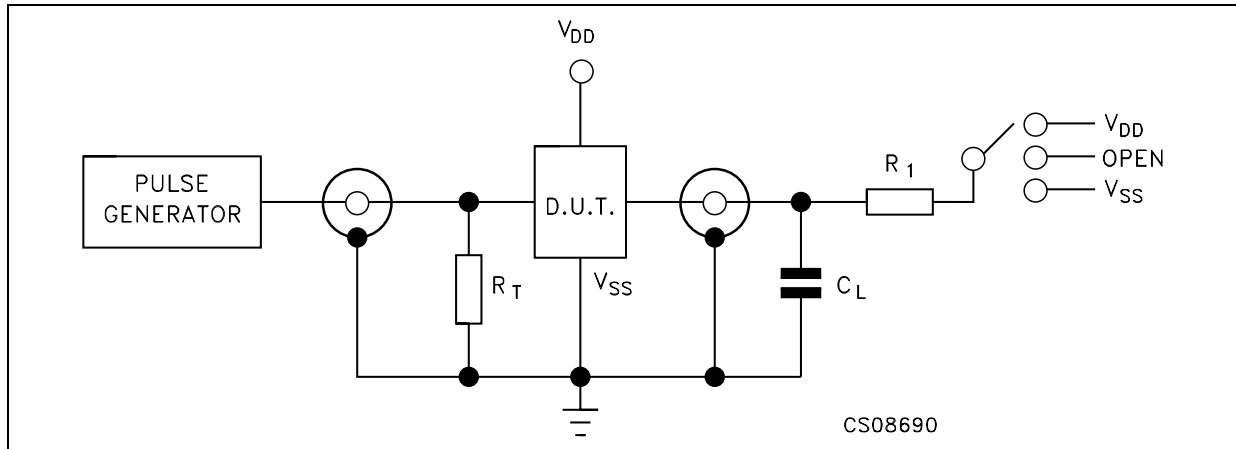

TEST	SWITCH
$t_{PLH}$ , $t_{PHL}$	Open
$t_{PZL}$ , $t_{PLZ}$	$V_{DD}$
$t_{PZH}$ , $t_{PHZ}$	$V_{SS}$

$C_L = 50\text{pF}$  or equivalent (includes jig and probe capacitance)

$R_L = 200\text{K}\Omega$

$R_T = Z_{OUT}$  of pulse generator (typically  $50\Omega$ )

WAVEFORM 1 : CK TO Q PROPAGATION DELAY TIMES ( $f=1\text{MHz}$ ; 50% duty cycle)

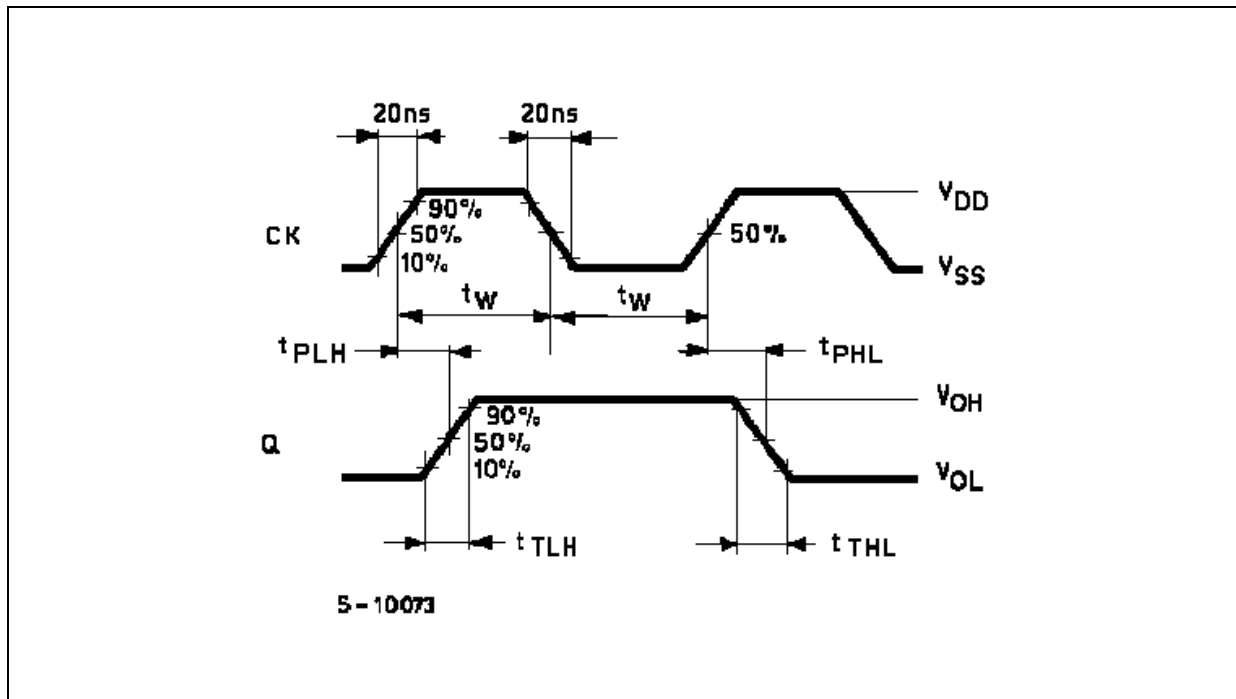

WAVEFORM 2 : SI, SO SETUP AND HOLD TIMES (f=1MHz; 50% duty cycle)

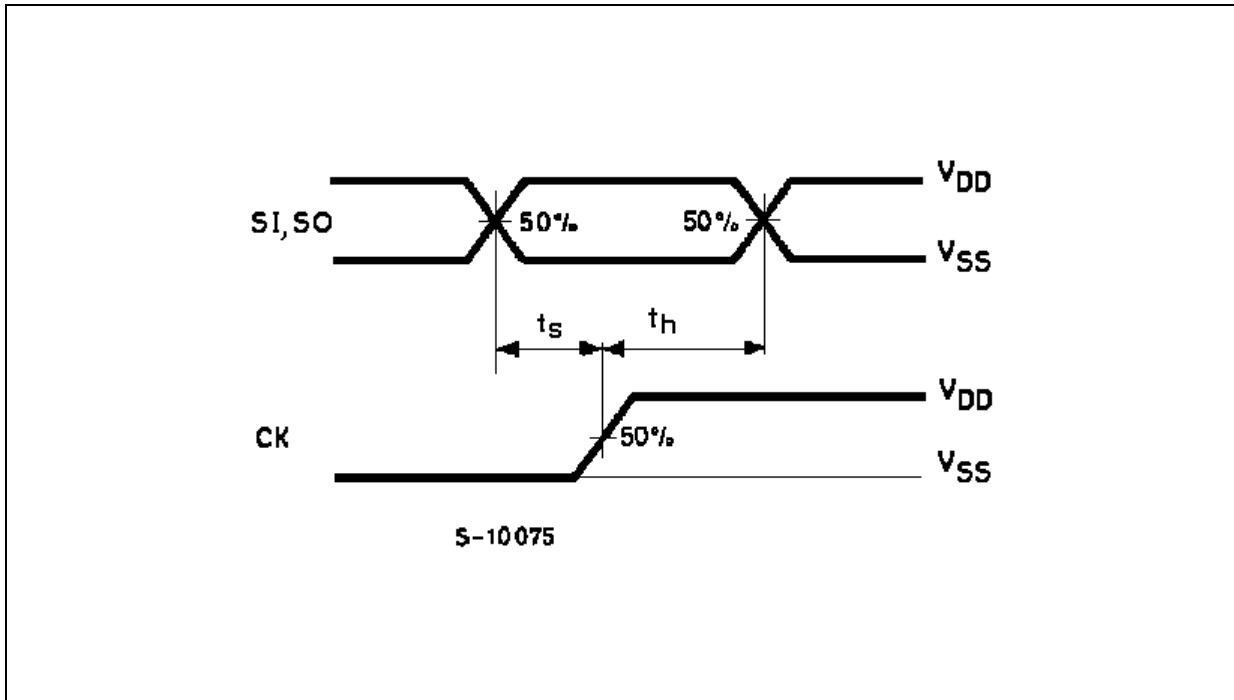

WAVEFORM 3 : OUTPUT ENABLE AND DISABLE TIMES (f=1MHz; 50% duty cycle)

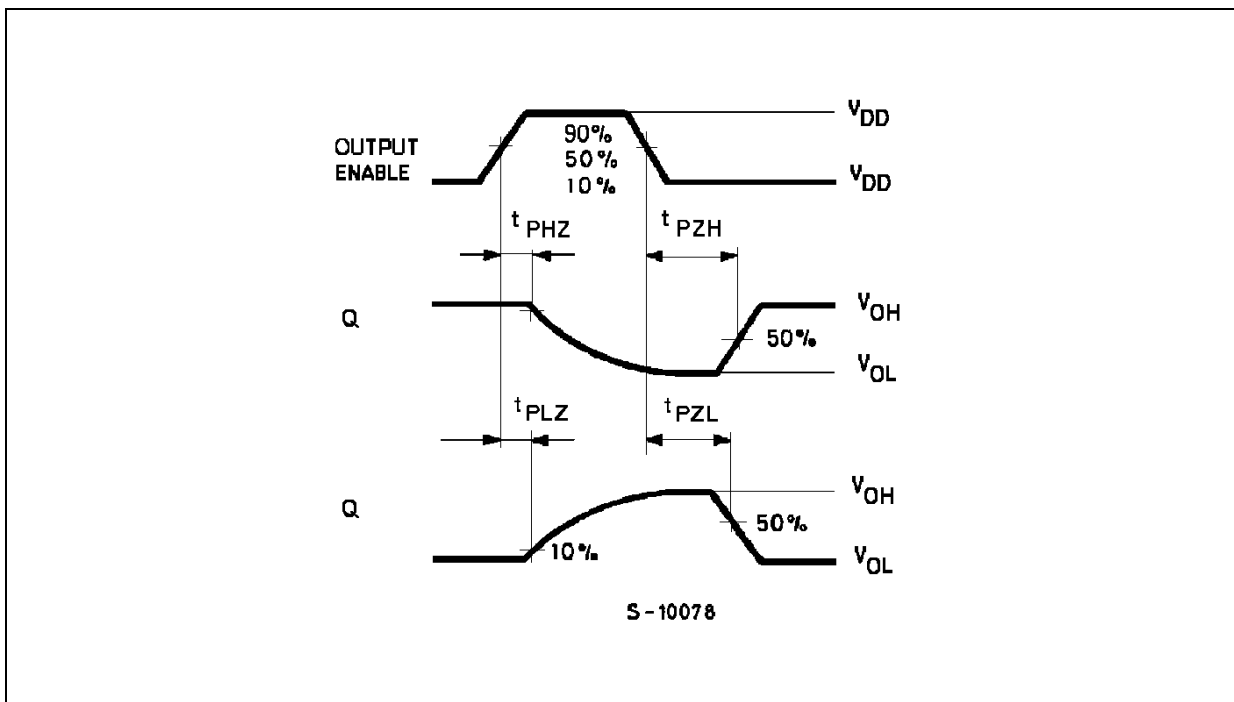



**Plastic DIP-16 (0.25) MECHANICAL DATA**

DIM.	mm.			inch		
	MIN.	TYP	MAX.	MIN.	TYP.	MAX.
a1	0.51			0.020		
B	0.77		1.65	0.030		0.065
b		0.5			0.020	
b1		0.25			0.010	
D			20			0.787
E		8.5			0.335	
e		2.54			0.100	
e3		17.78			0.700	
F			7.1			0.280
I			5.1			0.201
L		3.3			0.130	
Z			1.27			0.050

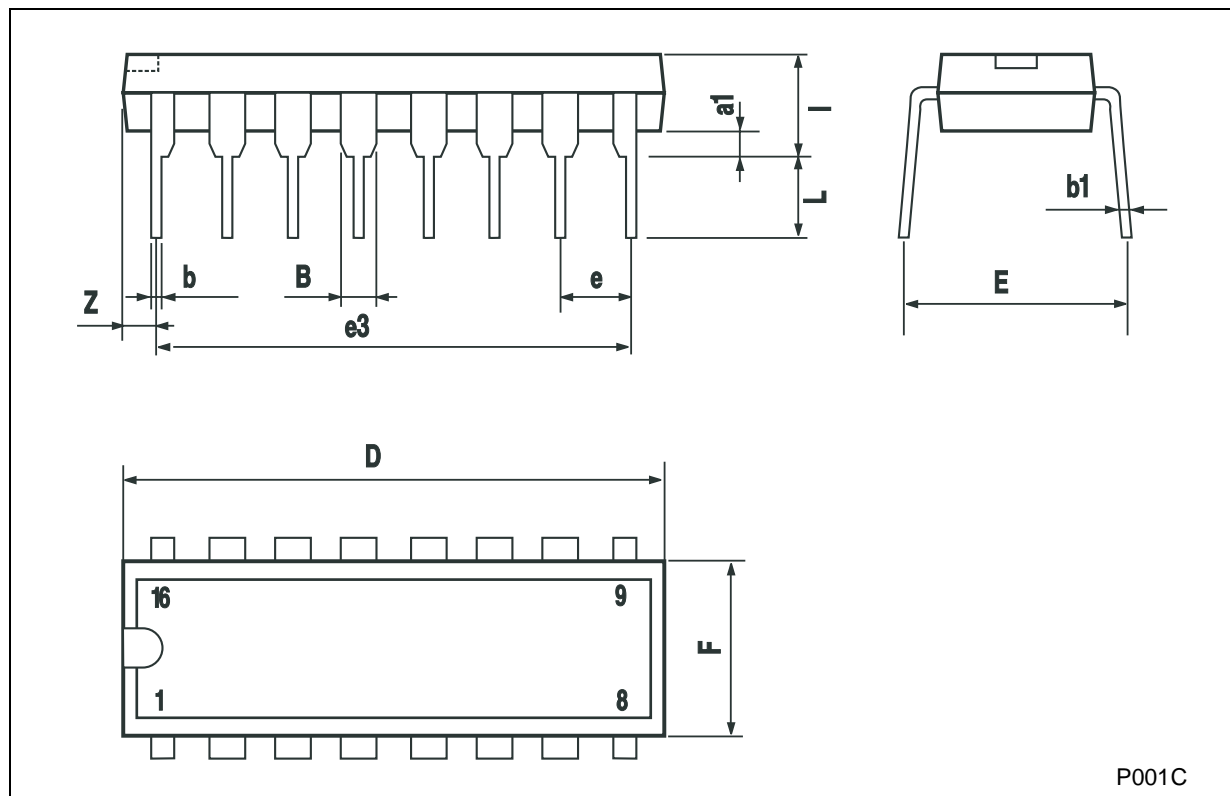

Information furnished is believed to be accurate and reliable. However, STMicroelectronics assumes no responsibility for the consequences of use of such information nor for any infringement of patents or other rights of third parties which may result from its use. No license is granted by implication or otherwise under any patent or patent rights of STMicroelectronics. Specifications mentioned in this publication are subject to change without notice. This publication supersedes and replaces all information previously supplied. STMicroelectronics products are not authorized for use as critical components in life support devices or systems without express written approval of STMicroelectronics.

© The ST logo is a registered trademark of STMicroelectronics

© 2002 STMicroelectronics - Printed in Italy - All Rights Reserved  
STMicroelectronics GROUP OF COMPANIES

Australia - Brazil - Canada - China - Finland - France - Germany - Hong Kong - India - Israel - Italy - Japan - Malaysia - Malta - Morocco  
Singapore - Spain - Sweden - Switzerland - United Kingdom - United States.

© <http://www.st.com>