

HA1319

AUDIO AMPLIFIER FOR TEPE RECORDER

■ FEATURES

- No transformer required thanks to complementary output circuit
- Excellent equalizer characteristics
- Low-distortion recording even if volumeless because of AGC circuit wide dynamic range.
- Wide supply voltage range, $V_{CC} \geq 4V$.



(DP-14)

■ CIRCUIT SCHEMATIC AND TYPICAL EXTERNAL PARTS

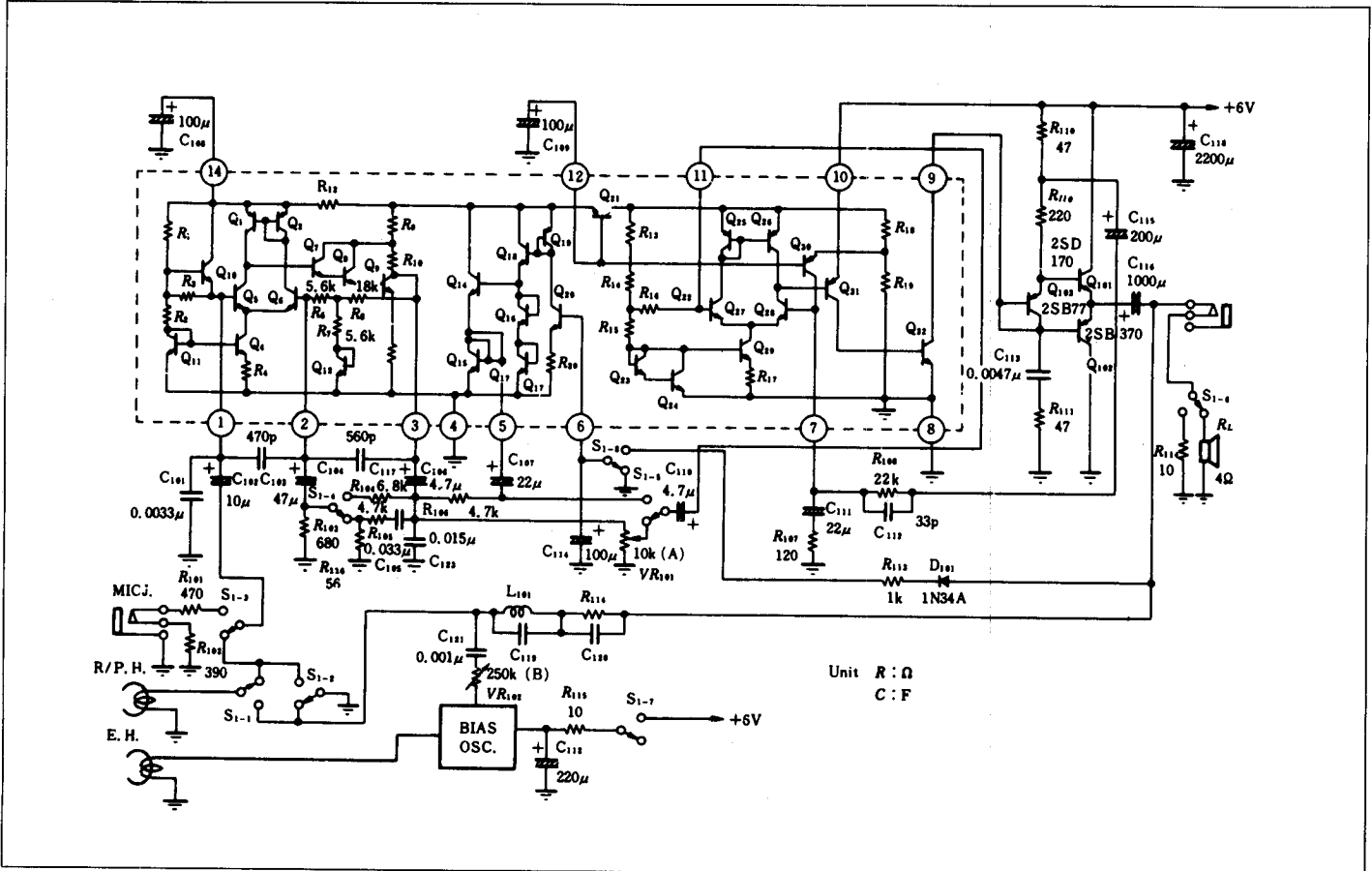

■ ABSOLUTE MAXIMUM RATINGS ($T_a = 25^\circ C$)

Item	Symbol	Rating	Unit
Supply Voltage	V_{CC}	12	V
Power Dissipation	P_T	400	mW
9-pin Current	I_9	30	mA
Operating Temperature	T_{op}	-10 to +70	$^\circ C$
Storage Temperature	T_{stg}	-55 to +125	$^\circ C$

* I_9 is the current to flow into 9-pin

ELECTRICAL CHARACTERISTICS ($V_{CC}=6V$, $R_L=4\Omega$, $f=1kHz$, $T_a=25^\circ C$) with output transistors

Item	Symbol	Test Condition	min	typ	max	Unit
Quiescent Current	I_c		10	15	20	mA
Output Power	P_o max	T.H.D=10% (play)	0.8	1.0	—	W
Voltage Gain	G_V	(play)	—	85	—	dB
Total Harmonic Distortion	T.H.D	$P_{out}=100mW$ (play)	—	0.5	1.8	%
Output Noise Voltage	V_n	$R_g=0$ (play)	—	17	30	mV
Input Resistance	Preamp	R_{in}	10	20	—	k Ω
	Drive Amp					
AGC Ratio	RATIO AGC	$V_{in}=-70dBm \rightarrow -30dBm$	—	30	—	dB
AGC Total Harmonic Distortion	T.H.D AGC	$V_{in}=-30dBm$ (rec)	—	1	—	%
Min Operating Voltage	V_{CC} min	(play)	4	—	—	V

Operating Considerations

Regarding the selection of external parts, refer to all of the following comments:

- (1) C_{101} : Capacitor for use as a compensator for high-frequency characteristics during playback.
Use C_{101} suitable for the characteristic of a head.
- (2) C_{102} : Capacitor to prevent being affected by waves of radio and television broadcasts.
Determine C_{103} experimentally, based on its being affected by pattern of the printed circuit board and the input wiring.
- (3) C_{117} ,
 C_{123} : Capacitors for use as prevention against preamplifier oscillations. C_{117} functions to eliminate high-frequency noise.
Use C_{117} in 500 to 1000pF.
- (4) C_{105} ,
 R_{105} ,
 R_{116} : These are used as playback equalizers.
The time constant is 125 μ sec at 4.75cm/s speed; however, they must be modified a trifle by a head characteristic and the required frequency characteristic. Voltage gain is about 40dB at $f=1kHz$ with the standard circuit.
- (5) R_{103} ,
 R_{104} : Resistors used to determine the preamplifier voltage gain while recording. G_V is approximately determined by $\frac{R_{104}}{R_{103}}$
If the voltage gain is rendered too high, the sphere of AGC activity will be a narrowed design G_V for 20dB.
- (6) R_{106} : Resistor used to divide the AGC voltage. While recording, the preamplifier output of pin 3 is added to the driver stage, being divided into R_{106} and output impedance of the AGC circuit.
- (7) C_{114} ,
 D_{101} ,
 R_{113} : C_{114} , D_{101} , and R_{113} are used as control signal rectifiers of the AGC circuit.
Use a germanium diode in D_{101} .
If C_{114} is rendered too large, the AGC will not operate immediately after a radical increase in recording input.
Conversely, on rendering it too small, sufficient rectification does not occur, and the AGC circuit is unstable.
Use a 100 μ F capacitor.
At tape stoppage, short C_{114} to discharge electricity.
 R_{113} is a damping resistor.
Use a resistor over 1k Ω .
- (8) C_{109} : Power ripple filter.
This is related to the rise time at power switch ON.
Use a 100~200 μ F capacitor.
- (9) R_{107} , R_{108} : Negative feedback resistor to determine voltage gain of the driver + output stage.

G_V is approximately determined as follows:

$$\frac{R_{108}}{R_{107}} = \left(\frac{22k\Omega}{120\Omega} = 183 \rightarrow 45dB \right)$$

- (10) $C_{112}, C_{113}, R_{111}$: The function of C_{112} and C_{113} are to prevent oscillation of the driver + output stage. Use a 30 to 60pF capacitor in C_{112} .
- (11) C_{115} : Bootstrap Capacitor. Use a capacitor over 100 μ F.
- (12) R_{109}, R_{110} : Resistors to determine the driving current of the output stage. Determine them as follows:

$$\frac{V_{CC}}{2(R_{109} + R_{110})} = 10 \text{ to } 15mA$$

- (13) Q_{101}, Q_{102} : Since R_{109} is arranged in parallel with the load resistance for AC, its value must be more than 10 times the load resistance. Use germanium power transistors in these. If use silicon power transistors are used, output power will be lowered. At $V_{CC} = 6V$ it decreases about 30%.
- (14) Q_{103} : Employed to let an idling current flow to the power transistors. When the power transistors are germanium, Q_{103} must be a germanium transistor or varistor. Q_{101} to Q_{103} should be mounted on the same heat sink.
- (15) R_{114}, C_{120} : These function as equalizers of the recording head. Choose that which is suitable to the recording head characteristic.
- (16) L_{101}, C_{119} : These are bias trap coils. The resonant frequency must equal the bias oscillation frequency.

■ PRINTED CIRCUIT BOARD (Bottom View)

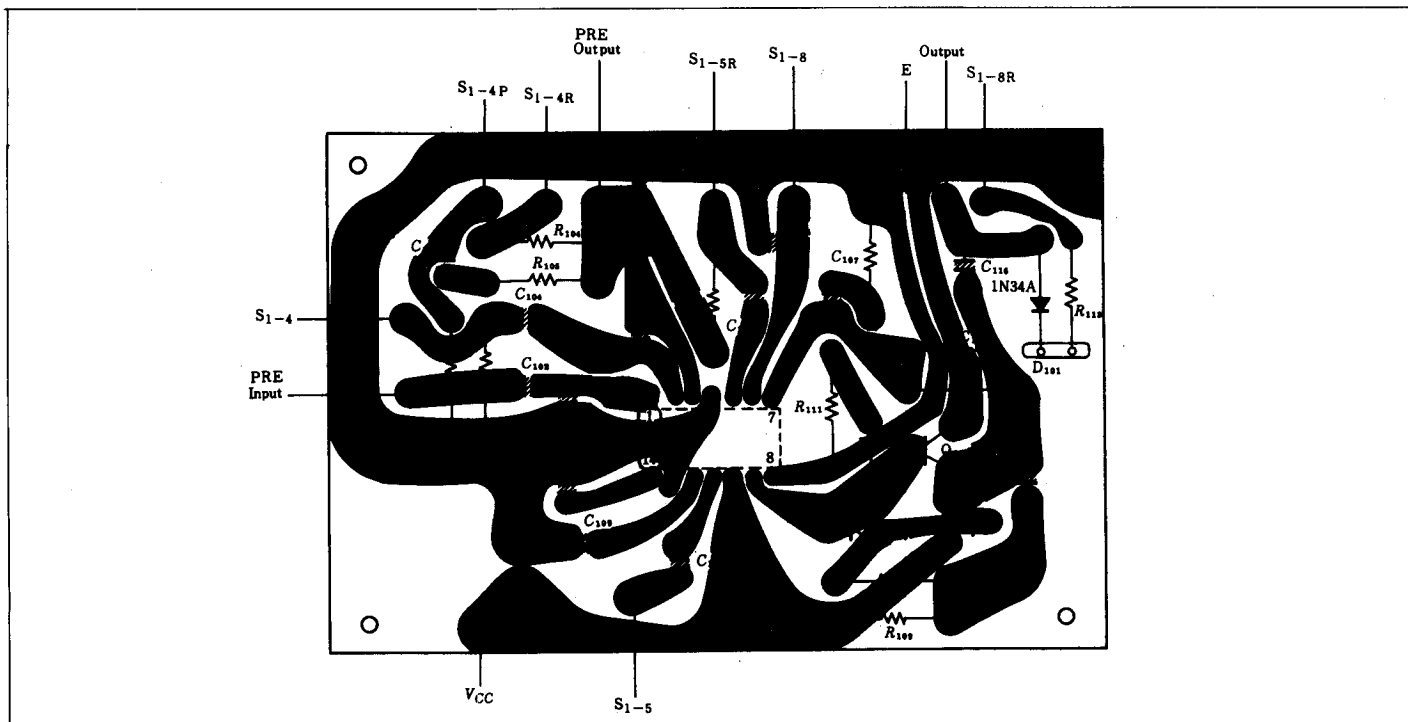

OUTPUT LEVEL AND TOTAL HARMONIC DISTORTION VS. INPUT LEVEL

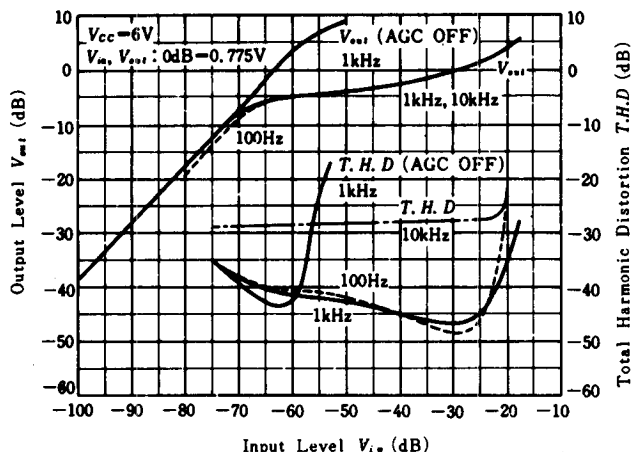

VOLTAGE GAIN VS. SUPPLY VOLTAGE

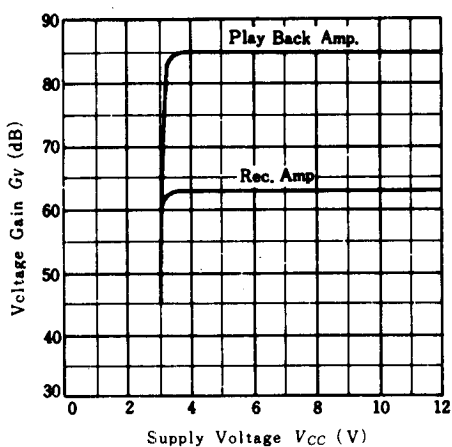

FREQUENCY CHARACTERISTICS OF PLAYBACK AMP. AND RECORDING AMP.

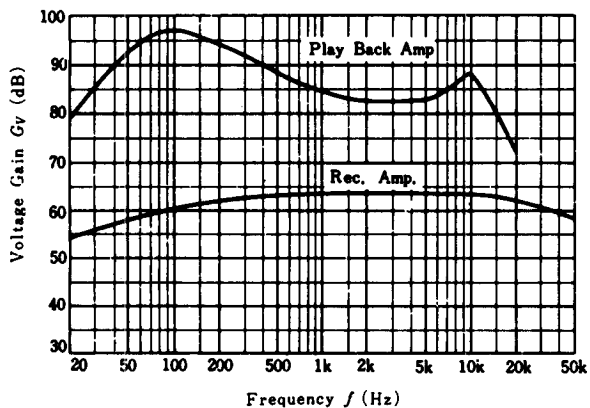

TOTAL HARMONIC DISTORTION VS. OUTPUT POWER (PLAYBACK AMP.)

