

# HA1151

## AM RADIO RECEIVER SYSTEM

### ■ FEATURES

- Low number of external parts
- Tuning meter circuit
- Wide AGC range

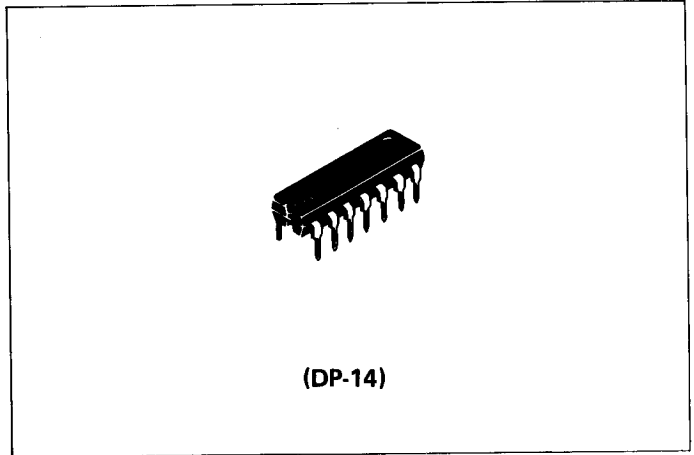

(DP-14)

### ■ CIRCUIT SCHEMATIC & EXTERNAL COMPONENTS

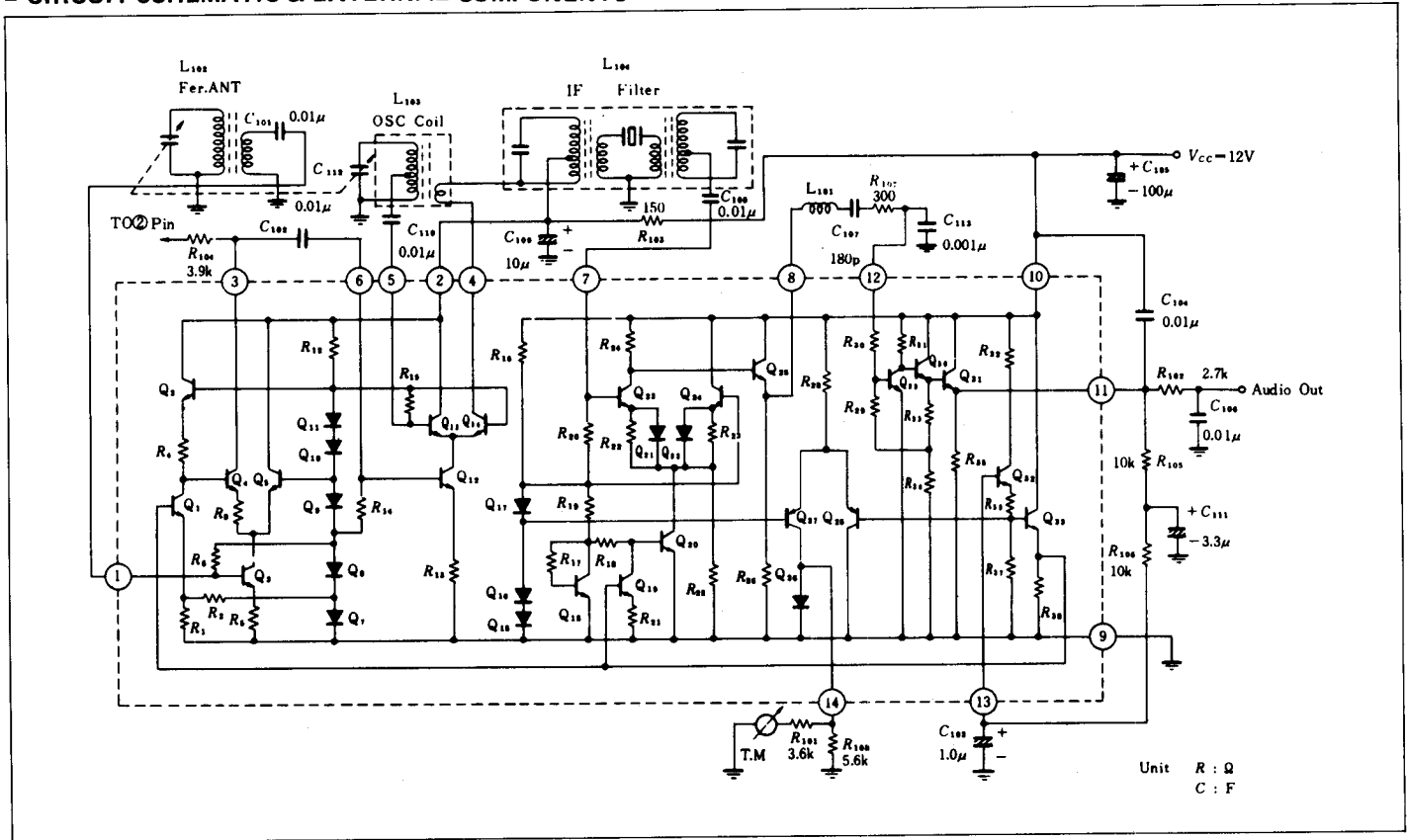

### ■ ABSOLUTE MAXIMUM RATINGS ( $T_a = 25^\circ\text{C}$ )

Item	Symbol	Rating	Unit
Supply Voltage	$V_{cc}$	18	V
Power Dissipation*	$P_T$	500	mW
Operating Temperature	$T_{opr}$	-30 to +70	$^\circ\text{C}$
Storage Temperature	$T_{stg}$	-55 to +125	$^\circ\text{C}$

\* Value at  $T_a = 70^\circ\text{C}$

■ ELECTRICAL CHARACTERISTICS ( $V_{cc}=12V$ ,  $f=1MHz$ ,  $f_m=400Hz$ ,  $T_a=25^\circ C$ )

Item	Symbol	Test Condition	min	typ	max	Unit
Signal-to-noise Ratio	S/N	Input = 40dB $\mu$ , Mod = 30%	12.0	16.0	—	dB
		Input = 74dB $\mu$ , Mod = 30%	—	46.0	—	
Total Harmonic Distortion	T.H.D	Input = 74dB $\mu$ , Mod = 30%	—	1.0	—	%
		Input = 74dB $\mu$ , Mod = 80%	—	1.5	3.0	
		Input = 106dB $\mu$ , Mod = 80%	—	2.5	—	
		Input = 120dB $\mu$ , Mod = 30%	—	2.5	—	
Tuning Meter Current	$I_M$	Input = 0dB $\mu$	—	0	—	$\mu A$
		Input = 120dB $\mu$	—	180	—	
Output Voltage	$V_o$		145	170	330	mV
Quiescent Current	$I_o$		—	13	—	mA

■ PRINTED CIRCUIT BOARD (Bottom View)

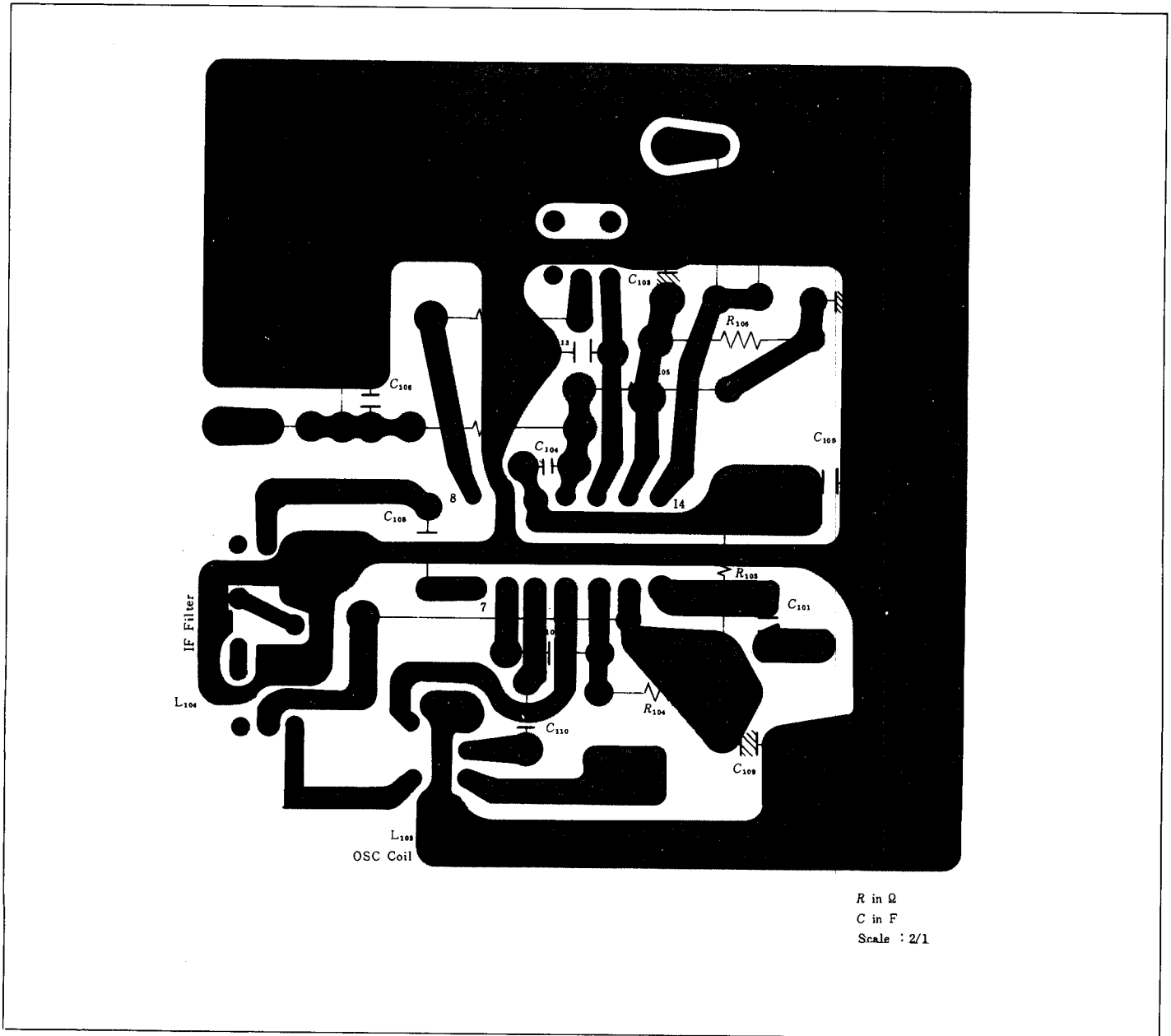

## SIGNAL-TO-NOISE RATIO, OUTPUT LEVEL AND TOTAL HARMONIC DISTORTION VS. INPUT LEVEL

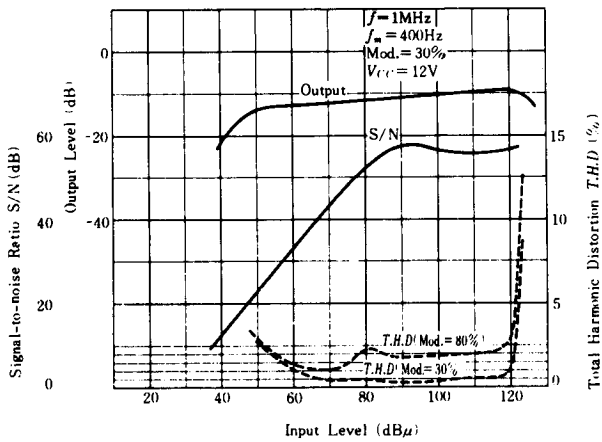

## TOTAL HARMONIC DISTORTION VS. MODULATION FREQUENCY

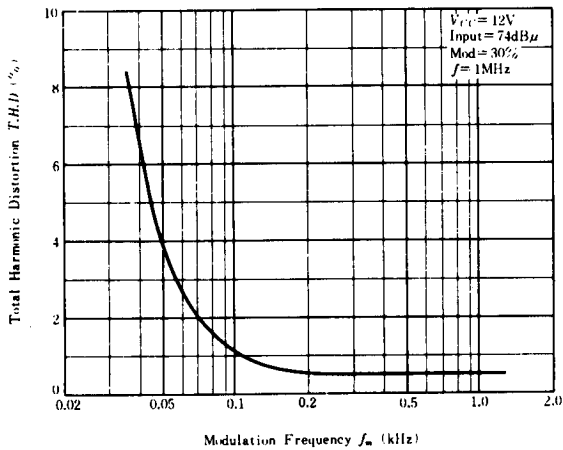

## MAXIMUM SENSITIVITY VS. SUPPLY VOLTAGE

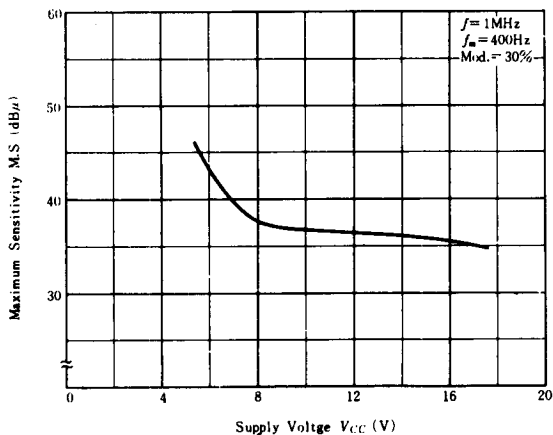

## COIL SPECIFICATIONS

### 1. IF Filter

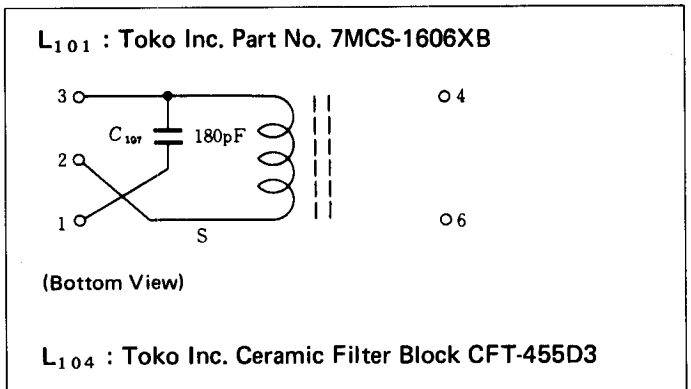

### 2. Local Oscillation Coil

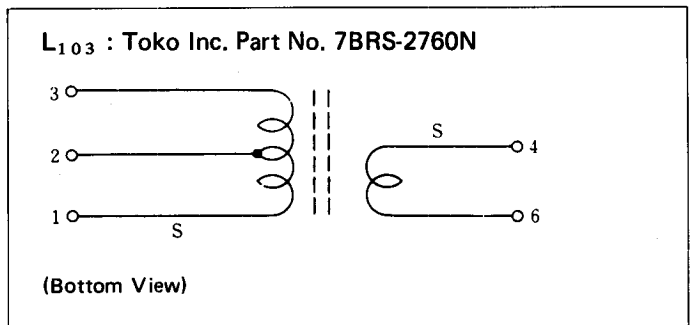

## QUIESCENT CURRENT VS. SUPPLY VOLTAGE

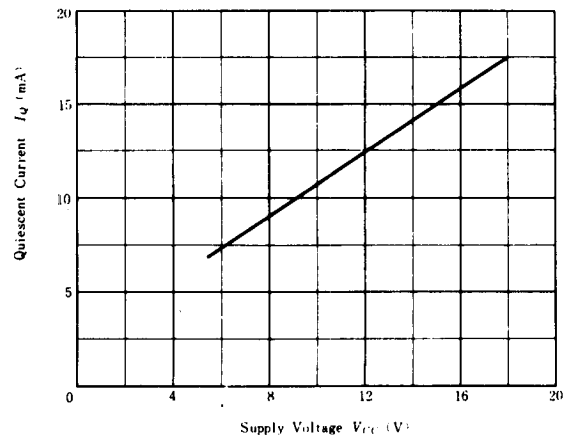

## SIGNAL-TO-NOISE RATIO VS. SUPPLY VOLTAGE

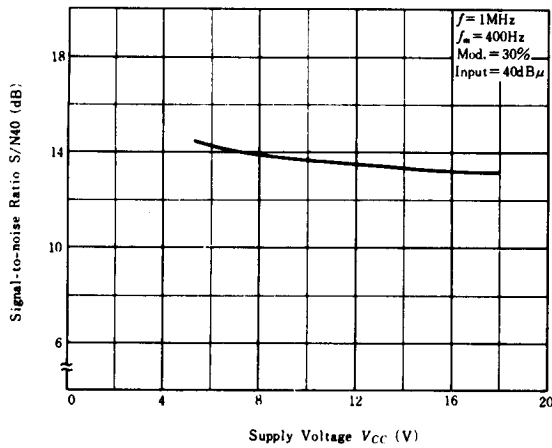

## TOTAL HARMONIC DISTORTION VS. SUPPLY VOLTAGE

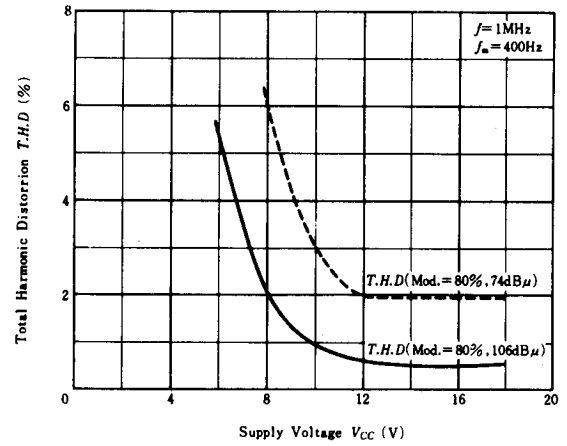

## AUDIO OUTPUT VOLTAGE VS. SUPPLY VOLTAGE

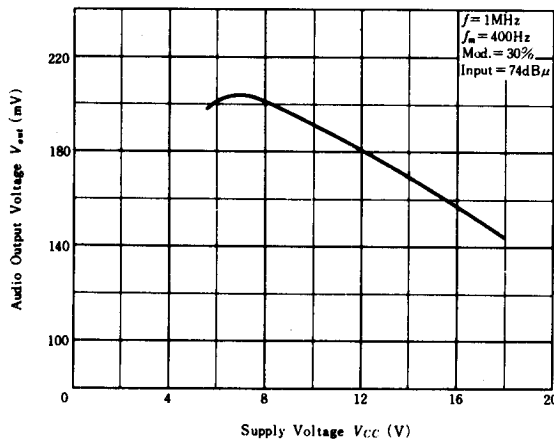

## EXTERNAL COMPONENTS

Parts No.	Recommended value	Purpose	Influence		Remarks
			Larger than Recommended Value	Smaller than Recommended Value	
R <sub>101</sub>	3.6k $\Omega$	Adjustment of tuning meter Sensitivity	—	Overscale of tuning meter	—
R <sub>104</sub>	3.9k $\Omega$	Load resistor of RF amplifier	Increase in RF gain. Abnormal operation of RF amplifier	Decrease in RF gain Poor S/N ratio	—
R <sub>105</sub> R <sub>106</sub>	10k $\Omega$ 10k $\Omega$	Ripple filter of AGC voltage	Decrease in THD. Poor AGC response.	Increase in THD Good AGC response	—
R <sub>107</sub>	300 $\Omega$	Gain control	Decrease in gain	Increase in gain. Instability	—
R <sub>108</sub>	5.6k $\Omega$	Damping of tuning meter	Rapid build up of tuning meter	Slow build up of tuning meter	—
C <sub>103</sub>	1.0 $\mu\text{F}$	Ripple filter of AGC voltage	Decrease in THD Poor AGC response	Increase in THD Good AGC response	—
C <sub>110</sub>	0.01 $\mu\text{F}$	Injection coupling capacitor of local oscillator	—	Decrease in oscillating loop gain Nonoscillation	—
C <sub>111</sub>	3.3 $\mu\text{F}$	Ripple filter of AGC voltage	Decrease in THD Poor AGC response	Increase in THD Good AGC response	—