

HIGH-FREQUENCY SATURATED SWITCH

DESCRIPTION

The 2N2368 is a silicon planar epitaxial NPN transistor in Jedec TO-18 metal case. It is designed specifically for high-speed saturated switching applications at current levels from 100 μ A to 100 mA.

 Products approved to CECC 50004-022/023 available on request.

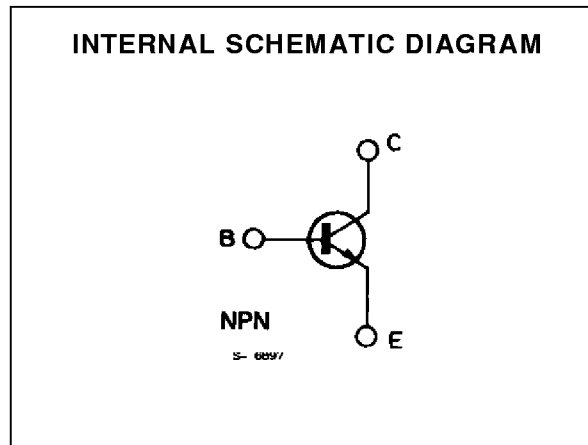
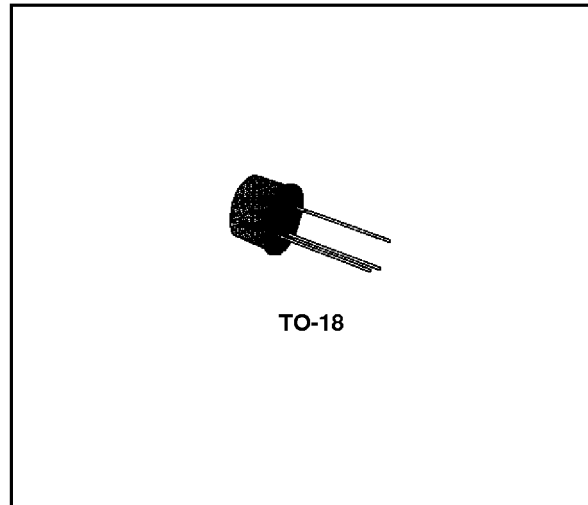

ABSOLUTE MAXIMUM RATINGS

| Symbol | Parameter | Value | Unit |
|----------------|---|-------------|------------------|
| V_{CBO} | Collector-base Voltage ($I_E = 0$) | 40 | V |
| V_{CES} | Collector-emitter Voltage ($I_{BE} = 0$) | 40 | V |
| V_{CEO} | Collector-emitter Voltage ($I_B = 0$) | 15 | V |
| V_{EBO} | Emitter-base Voltage ($I_C = 0$) | 4.5 | V |
| I_{CM} | Collector Peak Current ($t = 10 \mu s$) | 0.5 | A |
| P_{tot} | Total Power Dissipation at $T_{amb} \leq 25 \text{ }^\circ\text{C}$ | 0.36 | W |
| | at $T_{case} \leq 25 \text{ }^\circ\text{C}$ | 1.2 | W |
| | at $T_{case} \leq 100 \text{ }^\circ\text{C}$ | 0.68 | W |
| T_{stg}, T_j | Storage and Junction Temperature | - 65 to 200 | $^\circ\text{C}$ |

THERMAL DATA

| | | | | |
|------------------|-------------------------------------|-----|-----|---------------|
| $R_{th\ j-case}$ | Thermal Resistance Junction-case | Max | 146 | $^{\circ}C/W$ |
| $R_{th\ j-amb}$ | Thermal Resistance Junction-ambient | Max | 486 | $^{\circ}C/W$ |

ELECTRICAL CHARACTERISTICS ($T_{amb} = 25\ ^{\circ}C$ unless otherwise specified)

| Symbol | Parameter | Test Conditions | Min. | Typ. | Max. | Unit |
|-------------------|--|---|----------------|------|-----------|--------------------|
| I_{CBO} | Collector Cutoff Current ($I_E = 0$) | $V_{CB} = 20\ V$ $V_{CB} = 20\ V$ $T_{amb} = 150\ ^{\circ}C$ | | | 0.4 30 | μA μA |
| $V_{(BR)\ CBO}$ | Collector-base Breakdown Voltage ($I_E = 0$) | $I_C = 10\ \mu A$ | 40 | | | V |
| $V_{(BR)\ CES}$ | Collector-emitter Breakdown Voltage ($V_{BE} = 0$) | $I_C = 10\ \mu A$ | 40 | | | V |
| $V_{(BR)\ CEO}^*$ | Collector-emitter Breakdown Voltage ($I_B = 0$) | $I_C = 10\ mA$ | 15 | | | V |
| $V_{(BR)\ EBO}$ | Emitter-base Breakdown Voltage ($I_C = 0$) | $I_E = 10\ \mu A$ | 4.5 | | | V |
| $V_{CE(sat)}^*$ | Collector-emitter Saturation Voltage | $I_C = 10\ mA$ $I_B = 1\ mA$ | | 0.2 | 0.25 | V |
| $V_{BE(sat)}^*$ | Base-emitter Saturation Voltage | $I_C = 10\ mA$ $I_B = 1\ mA$ | 0.7 | 0.75 | 0.85 | V |
| h_{FE}^* | DC Current Gain | $I_C = 10\ mA$ $V_{CE} = 1\ V$ $I_C = 100\ mA$ $V_{CE} = 2\ V$ $I_C = 10\ mA$ $V_{CE} = 1\ V$ $T_{amb} = -55\ ^{\circ}C$ | 20 10 10 | | 60 | |
| f_T | Transition Frequency | $I_C = 10\ mA$ $V_{CE} = 10\ V$ $f = 100\ MHz$ | 400 | 550 | | MHz |
| C_{CBO} | Collector-base Capacitance | $I_E = 0$ $V_{CB} = 5\ V$ $f = 1\ MHz$ | | 2.5 | 4 | pF |
| t_s | Storage Time | $I_C = 10\ mA$ $V_{CC} = 10\ V$ $I_{B1} = -$ $I_{B2} = 10\ mA$ | | 5 | 10 | ns |
| t_{on} | Turn-on Time | $I_C = 10\ mA$ $V_{CC} = 3\ V$ $I_{B1} = 3\ mA$ | | 9 | 12 | ns |
| t_{off} | Turn-off Time | $I_C = 10\ mA$ $V_{CC} = 3\ V$ $I_{B1} = 3\ mA$ $I_{B2} = -1.5\ mA$ | | 10 | 15 | ns |

* Pulsed : pulse duration = 300 μs , duty cycle = 1 %.

TO-18 MECHANICAL DATA

| DIM. | mm | | | inch | | |
|------|------|------|------|-------|-------|-------|
| | MIN. | TYP. | MAX. | MIN. | TYP. | MAX. |
| A | | 12.7 | | | 0.500 | |
| B | | | 0.49 | | | 0.019 |
| D | | | 5.3 | | | 0.208 |
| E | | | 4.9 | | | 0.193 |
| F | | | 5.8 | | | 0.228 |
| G | 2.54 | | | 0.100 | | |
| H | | | 1.2 | | | 0.047 |
| I | | | 1.16 | | | 0.045 |
| L | 45° | | | 45° | | |

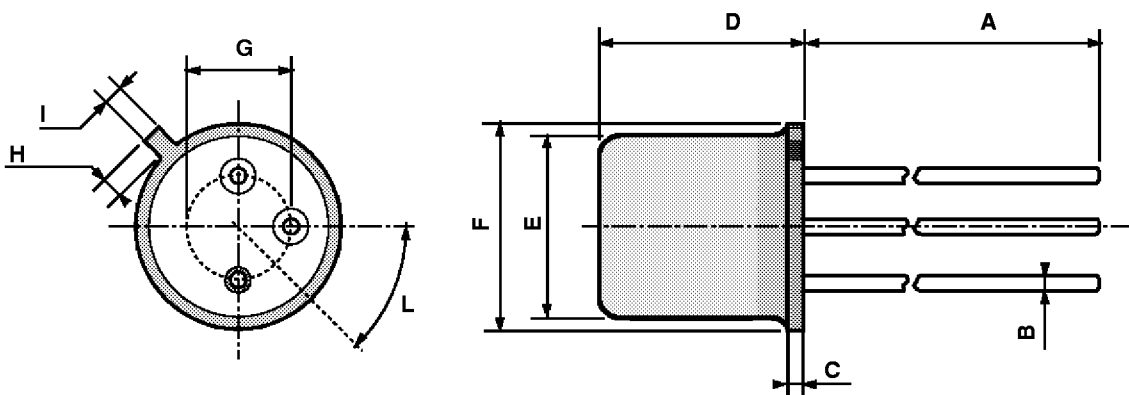

0016043

Information furnished is believed to be accurate and reliable. However, SGS-THOMSON Microelectronics assumes no responsibility for the consequences of use of such information nor for any infringement of patents or other rights of third parties which may result from its use. No license is granted by implication or otherwise under any patent or patent rights of SGS-THOMSON Microelectronics. Specifications mentioned in this publication are subject to change without notice. This publication supersedes and replaces all information previously supplied. SGS-THOMSON Microelectronics products are not authorized for use as critical components in life support devices or systems without express written approval of SGS-THOMSON Microelectronics.

© 1994 SGS-THOMSON Microelectronics - All Rights Reserved

SGS-THOMSON Microelectronics GROUP OF COMPANIES
Australia - Brazil - France - Germany - Hong Kong - Italy - Japan - Korea - Malaysia - Malta - Morocco - The Netherlands -
Singapore - Spain - Sweden - Switzerland - Taiwan - Thailand - United Kingdom - U.S.A