

Technical data sheet

Interface Technology · LCIS temperature/analog converter

Input: Thermal elements J, K
Output: 0–10 V / 0–20 mA / 4–20 mA
Insulation: 4.0 kV, 3-way isolation



Identification

Type LCIS-WP-WTCA-0848-175-S
Part No. [750848.0000](#)

Product version

Hardware revision 1.0
Software version 1.0
Datasheet version 01

Input

Input variable Thermo voltage, element J or K (DIN/IEC 584-1)
Galvanic isolation I/O 3-way isolation
Measuring procedure Voltage measurement
Temperature range J: -50 °C–150 °C / -50 °C–250 °C / -50 °C–350 °C / 0 °C–400 °C / 0 °C–600 °C / 0 °C–800 °C / 0 °C–1000 °C / 0 °C–1200 °C
K: -210 °C–105 °C / -50 °C–250 °C / -50 °C–350 °C / 0 °C–400 °C / 0 °C–600 °C / 0 °C–800 °C / 0 °C–1000 °C / 0 °C–1200 °C
Parameterisation DIP switch S1
Zero /Span Production comparison
Input resistance >1 M Ω
Cold junction compensation throughout the entire temperature range
Protection device Input Overvoltage protection

Output

Output signal 0–10 V, 0–20 mA, 4–20 mA
Max. load impedance at I-output 500 Ω

United Kingdom: LÜTZE Ltd.

Unit 3, Sandy Hill Park
Sandy Way, Amington · GB-Tamworth, Staffs B77 4DU
Tel. +44 (0)1827 31333-0 · Fax +44 (0)1827 31333-2
www.lutze.com · sales.gb@lutze.co.uk

Germany: Friedrich Lütze GmbH

Postfach 12 24 (PLZ 71366) · Bruckwiesenstraße 17-19 · D-71384 Weinstadt
Tel. +49 (0)7151 6053-0 · Fax +49 (0)7151 6053-277(-288)
www.luetze.de · info@luetze.de

12.12.2023 · Subject to technical modification
Part No. [750848.0000](#) · Datasheet version: 01

Technical data sheet

Interface Technology · LCIS temperature/analog converter

Min. load impedance at U-output	2 k Ω
Load deviation	at U-output max. 5 mV @ 2 k Ω
Output voltage	<18 V @ 0–20 mA, 4–20 mA
Output current	max. 5 mA @ 10 V
Residual ripple	<20 mV _{eff}
Parameterisation	DIP switch S1
Protection device	short circuit protection

Operating data

Accuracy	0.5 % + 2K FSR @ 23 °C
Linearity error	0.1 % FSR, temperature linear
Rise time (10-90%)	approx. 30 ms @ 23 °C
Build-up time (Accuracy 1%)	approx. 60 ms @ 23 °C
Temperature coefficient	150 ppm / K FSR
Critical frequency	10 Hz @ 3 dB / 23 °C

General

Rated voltage U _N	AC/DC 24–240 V
Rated current	appr. 22 mA @ AC 24 V / appr. 19 mA @ DC 24 V
Status indication	LED green
Insulation voltage input / output	4.0 kV _{eff}
Housing material	PA 6.6 (UL 94 V-0, NFF I2, F2)
Color of the housing	RAL 7012 basalt grey
Mounting	DIN rail mountable TS35 (EN 60715)
Degree of protection	IP20
Installation position	Any
Connection type	Screwed terminal single wire 0.25 mm ² – 2.5 mm ² / AWG 24–14 fine stranded wire with ferrule 0.25 mm ² – 1.5 mm ² / AWG 24–16
Dimensions (w × h × d)	17.5 mm × 93.0 mm × 73.0 mm
Weight/unit	0.059 kg
PU (units)	1

General ambient conditions

Operation temperature range	-25 °C ... +60 °C
Storage temperature range	-40 °C ... +85 °C
Relative air humidity	20 – 90 % RH, not condensing
Vibration resistance	0.7 g acc. to EN 60068-2-6

Technical data sheet

Interface Technology · LCIS temperature/analog converter

Failure Rate Prediction (MTBF)

Standards	Electronic components – Reliability – Reference conditions for failure rates and stress models for conversion: EN/IEC 61709 Failure Rates of Components – Expected values: SN 29500
Failure rate at +45 °C	700 fit
Failure rate at +45 °C	1428555 h
	1 fit equals one failure per 10 ⁹ component hours
	The indicated temperature is the mean component ambient temperature.
Comments	The results are valid under following conditions: Automotive environment or industrial areas without extreme dust levels and harmful substances Continuous operation 8760 h per year

Certifications/Standards

Conformity	CE UKCA
Certifications	cULus (E135145) DNV (TAA000024Y)
Standards	EN 60947-1 EN 60947-5-1 UL 508 DNV-CG-0339

Dimensions

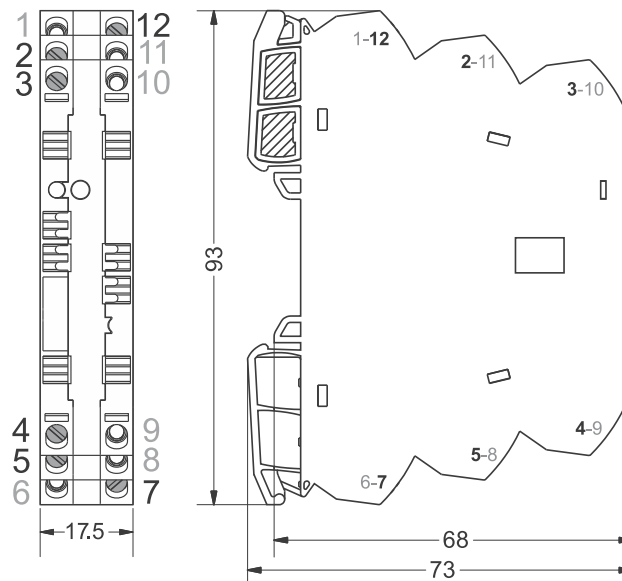

PIN assignment

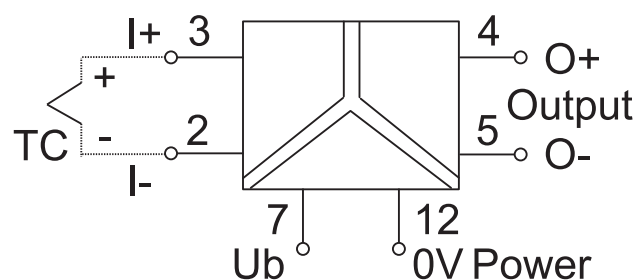

Technical data sheet

Interface Technology · LCIS temperature/analog converter

Use

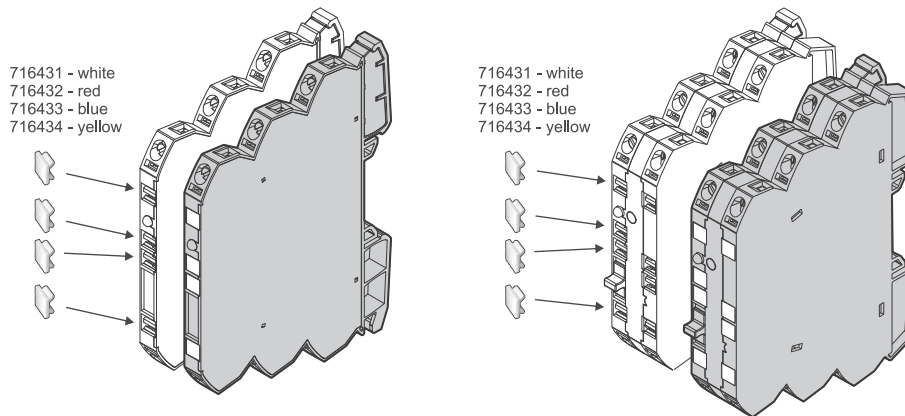

Use

DE HINWEIS: Die Schalter dürfen während des Betriebs nicht umgeschaltet werden. Der Wandler benötigt einen Neustart.

EN NOTICE: The switches must not be switched during operation. The converter requires a restart.

FR AVIS: Les interrupteurs ne doivent pas être actionnés pendant le fonctionnement. Le convertisseur nécessite un redémarrage.

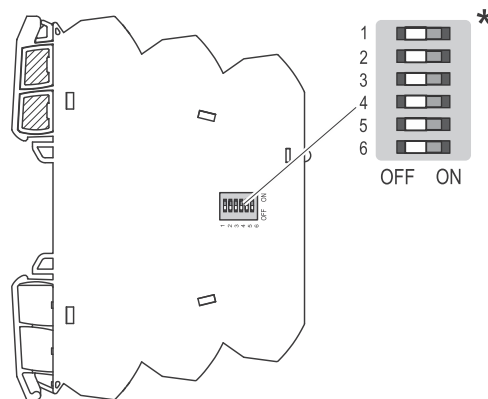

* **DE:** Auslieferungszustand (Werkseinstellung): 0-Einstellung/ alle Schalter sind auf OFF gestellt.

* **EN:** Delivery state (factory setting): 0 setting/ all switches are set to OFF.

* **FR:** État à la livraison (réglage d'usine) : réglage 0/ tous les interrupteurs sont sur OFF.

Technical data sheet

Interface Technology · LCIS temperature/analog converter

Range adjustment

S1	Output
• → Switch On	5 6
0–10V	●
0–20mA	●
4–20mA	●●

S1	Input
• → Switch On	1 2 3 4
TC J (Fe-CuNi)	
TC K (Ni-CrNi)	●
J: -50 – 150°C	
K: -210 – 105°C	
-50 – 250°C	●
-50 – 350°C	●
0 – 400°C	●●
0 – 600°C	●●
0 – 800°C	●●●
0 – 1000°C	●●●
0 – 1200°C	●●●