

## Technical data sheet

Interface Technology · LCIS temperature/analog converter

---

**Input: PT100, 2-wire/3-wire**

**Output: 0–10 V / 0–20 mA / 4–20 mA**

**Insulation: 2.5 kV, 2-way isolation**



---

### Identification

Type	LCIS-WPT3LA-0819-62-S
Part No.	<a href="#">750819.0000</a>

---

### Product version

Hardware revision	1.0
Software version	1.0
Datasheet version	01

---

### Input

Input variable	Temperature sensor PT100
Galvanic isolation I/O	2-way isolation
Measuring procedure	2-wire or 3-wire, constant current
Temperature range	-50 °C–50 °C / -50 °C–100 °C / -50 °C–150 °C / 0 °C–100 °C / 0 °C–150 °C / 0 °C–200 °C / 0 °C–300 °C / 0 °C–400 °C
Parameterisation	DIP switch S1
Zero /Span	Production comparison
Input resistance	>1 MΩ @ 2-wire, >500 kΩ @ 3-wire
Sensor current	0.5 mA
Protection device Input	Overvoltage protection

---

### Output

Output signal	0–10 V, 0–20 mA, 4–20 mA
Max. load impedance at I-output	500 Ω
Min. load impedance at U-output	2 kΩ
Load deviation	at U-output max. 5 mV @ 2 kΩ

---

#### United Kingdom: LÜTZE Ltd.

Unit 3, Sandy Hill Park  
Sandy Way, Amington • GB-Tamworth, Staffs B77 4DU  
Tel. +44 (0)1827 31333-0 • Fax +44 (0)1827 31333-2  
[www.lutze.com](http://www.lutze.com) • [sales.gb@lutze.co.uk](mailto:sales.gb@lutze.co.uk)

#### Germany: Friedrich Lütze GmbH

Postfach 12 24 (PLZ 71366) • Bruckwiesenstraße 17-19 • D-71384 Weinstadt  
Tel. +49 (0)7151 6053-0 • Fax +49 (0)7151 6053-277(-288)  
[www.luetze.de](http://www.luetze.de) • [info@luetze.de](mailto:info@luetze.de)

12.12.2023 • Subject to technical modification  
Part No. [750819.0000](#) • Datasheet version: 01

## Technical data sheet

### Interface Technology · LCIS temperature/analog converter

---

Output voltage	<16 V @ 0–20 mA, 4–20 mA
Output current	max. 5 mA @ 10 V
Residual ripple	<20 mV <sub>eff</sub>
Parameterisation	DIP switch S1
Protection device	short circuit protection

---

#### Operating data

---

Accuracy	0.3 % FSR @ 23 °C
Linearity error	0.1 % FSR
Rise time (10-90%)	approx. 30 ms @ 23 °C
Build-up time (Accuracy 1%)	approx. 60 ms @ 23 °C
Temperature coefficient	150 ppm / K FSR
Critical frequency	10 Hz @ 3 dB / 23 °C
Error coefficient of measuring line	2-conductor: 2.7 K/Ω, 3-conductor: 0.1 K + 0.1 %/Ω

---

#### General

---

Rated voltage U <sub>N</sub>	AC/DC 24 V
Rated current	approx. 22 mA @ AC 24 V / approx. 13 mA @ DC 24 V
Status indication	LED green
Insulation voltage input / output	2.5 kV <sub>eff</sub>
Housing material	PA 6.6 (UL 94 V-0, NFF I2, F2)
Color of the housing	RAL 7012 basalt grey
Mounting	DIN rail mountable TS35 (EN 60715)
Degree of protection	IP20
Installation position	Any
Connection type	Screwed terminal single wire 0.25 mm <sup>2</sup> – 2.5 mm <sup>2</sup> / AWG 24–14 fine stranded wire with ferrule 0.25 mm <sup>2</sup> – 1.5 mm <sup>2</sup> / AWG 24–16
Dimensions (w × h × d)	6.2 mm × 93.0 mm × 73.0 mm
Weight/unit	0.03 kg
PU (units)	1

---

#### General ambient conditions

---

Operation temperature range	-25 °C ... +60 °C
Storage temperature range	-40 °C ... +85 °C
Relative air humidity	20 – 90 % RH, not condensing
Vibration resistance	0.7 g acc. to EN 60068-2-6

---

#### Failure Rate Prediction (MTBF)

---

Standards	Electronic components – Reliability – Reference conditions for failure rates and stress models for conversion: EN/IEC 61709 Failure Rates of Components – Expected values: SN 29500
-----------	--

---

## Technical data sheet

### Interface Technology · LCIS temperature/analog converter

Failure rate at +45 °C	578 fit
Failure rate at +45 °C	1729323 h
	1 fit equals one failure per $10^9$ component hours
	The indicated temperature is the mean component ambient temperature.
Comments	The results are valid under following conditions: Automotive environment or industrial areas without extreme dust levels and harmful substances Continuous operation 8760 h per year

### Certifications/Standards

Conformity	CE UKCA
Certifications	cULus (E135145) DNV (TAA000024Y)
Standards	EN 60947-1 EN 60947-5-1 UL 508 DNV-CG-0339

### Dimensions

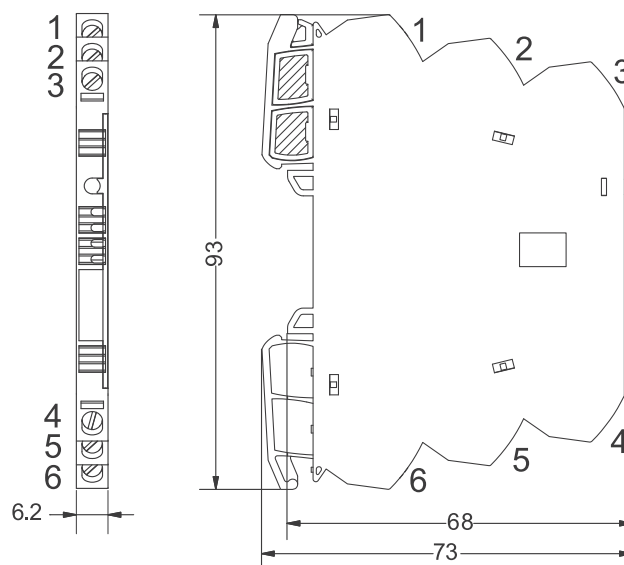

### PIN assignment

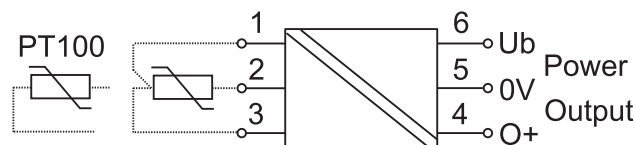

## Technical data sheet

### Interface Technology · LCIS temperature/analog converter

#### Use

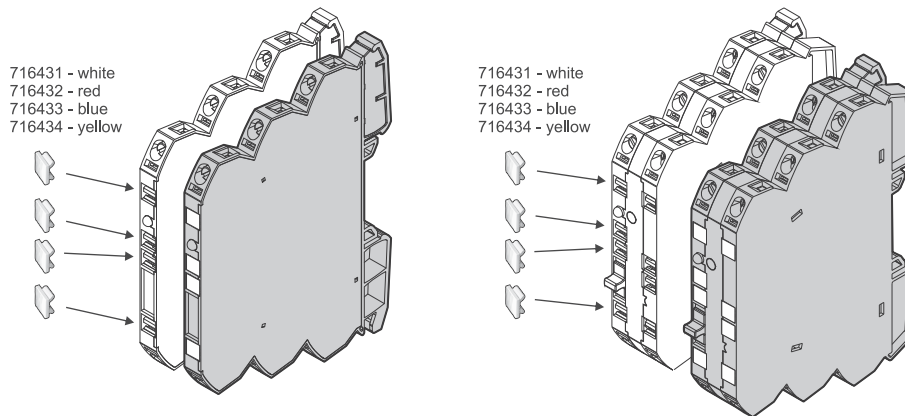

#### Use

**DE HINWEIS:** Die Schalter dürfen während des Betriebs nicht umgeschaltet werden. Der Wandler benötigt einen Neustart.

**EN NOTICE:** The switches must not be switched during operation. The converter requires a restart.

**FR AVIS:** Les interrupteurs ne doivent pas être actionnés pendant le fonctionnement. Le convertisseur nécessite un redémarrage.

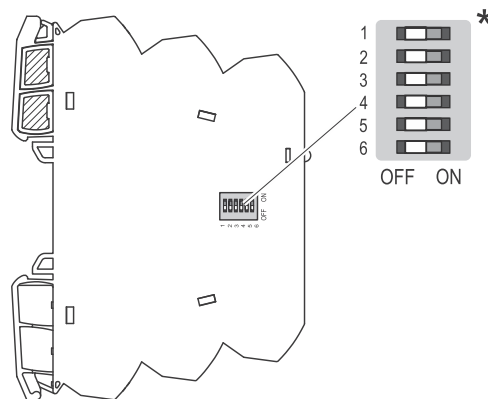

\* **DE:** Auslieferungszustand (Werkseinstellung): 0-Einstellung/ alle Schalter sind auf OFF gestellt.

\* **EN:** Delivery state (factory setting): 0 setting/ all switches are set to OFF.

\* **FR:** État à la livraison (réglage d'usine) : réglage 0/ tous les interrupteurs sont sur OFF.

## Technical data sheet

Interface Technology · LCIS temperature/analog converter

---

### Range adjustment

S1	Output
• → Switch On	5 6
0–10V	●
0–20mA	●
4–20mA	●●

S1	Input
• → Switch On	1 2 3 4
PT100, 3-wire	
PT100, 2-wire	●
-50 – 50°C	
-50 – 100°C	●
-50 – 150°C	●
0 – 100°C	●●
0 – 150°C	●●
0 – 200°C	●●
0 – 300°C	●●
0 – 400°C	●●●