

Technical data sheet

Interface Technology · LCIS analog/analog converter

Input: 16 selectable ranges

Output: 0–10 V / 0–20 mA / 4–20 mA

Insulation 2,5 kV, 3-way isolation



Identification

Type	LCIS-WUAA-0516-175-S
Part No.	750516.0000

Product version

Hardware revision	1.0
Software version	1.1
Datasheet version	01

Input

Input signal	0–60, 0–100, 0–300, 0–500 mV adjustable via DIP switch S1 0–1, 0–2, 0–5, 0–10, 0–20, 2–10 V adjustable via DIP switch S1 0–5, 0–10, 0–20, 4–20, ±5, ±20 mA adjustable via DIP switch S1
Galvanic isolation I/O	3-way isolation
Zero /Span	Production comparison
Input resistance	>330 kΩ @ mV, V, <100 Ω @ mA

Output

Output signal	0–10 V, 0–20 mA, 4–20 mA, adjustable via switch
Output voltage limit	min 0 V max 10.8 V for all output ranges with nominal upper limit 10 V
Output current limit	min. 0 mA for all output ranges with nominal lower limit 0 mA min. 3.6 mA or all output ranges 4 – 20 mA max. 21.6 mA for all output ranges with nominal upper limit 20 mA
Max. load impedance at I-output	500 Ω @ 0–20 mA, 4–20 mA
Min. load impedance at U-output	2 kΩ @ 0–10 V

United Kingdom: LÜTZE Ltd.

Unit 3, Sandy Hill Park
Sandy Way, Amington • GB-Tamworth, Staffs B77 4DU
Tel. +44 (0)1827 31333-0 • Fax +44 (0)1827 31333-2
www.lutze.com • sales.gb@lutze.co.uk

Germany: Friedrich Lütze GmbH

Postfach 12 24 (PLZ 71366) • Bruckwiesenstraße 17-19 • D-71384 Weinstadt
Tel. +49 (0)7151 6053-0 • Fax +49 (0)7151 6053-277(-288)
www.luetze.de • info@luetze.de

12.12.2023 • Subject to technical modification
Part No. [750516.0000](#) • Datasheet version: 01

page 1 of 5



SYSTEMATIC TECHNOLOGY

Technical data sheet

Interface Technology · LCIS analog/analog converter

Load deviation	at U-output max. 5 mV @ 2 k Ω
Output voltage	<18 V @ 0–20 mA, 4–20 mA
Output current	max. 5 mA @ 0–10 V
Residual ripple	<20 mV _{eff}

Operating data

Accuracy	0.1 % FSR @ 23 °C
Linearity error	0.05 % FSR
Rise time (10-90%)	6 ms
Build-up time (Accuracy 1%)	17 ms
Temperature coefficient	<150 ppm / K FSR
Critical frequency	30 Hz @ 3 dB

General

Rated voltage U _N	AC/DC 24 V
Current Consumption	19 mA
Status indication	LED green
Input/output protection	Overvoltage, current input with PTC fuse, short circuit-proof output
Insulation voltage input / output	2.5 kV _{eff}
Housing material	PA 6.6 (UL 94 V-0, NFF I2, F2)
Color of the housing	RAL 7012 basalt grey
Mounting	DIN rail mountable TS35 (EN 60715)
Degree of protection	IP20
Installation position	Any
Connection type	Screwed terminal single wire 0.25 mm ² – 2.5 mm ² / AWG 24–14 fine stranded wire with ferrule 0.25 mm ² – 1.5 mm ² / AWG 24–16
Strip length	6 mm
Dimensions (w × h × d)	17.5 mm × 93.0 mm × 73.0 mm
Weight/unit	0.059 kg
PU (units)	1

General ambient conditions

Operation temperature range	-25 °C ... +60 °C
Storage temperature range	-40 °C ... +80 °C
Relative air humidity	20 – 90 % RH, not condensing
Vibration resistance	0.7 g acc. to EN 60068-2-6

Failure Rate Prediction (MTBF)

Standards	Electronic components – Reliability – Reference conditions for failure rates and stress models for conversion: EN/IEC 61709 Failure Rates of Components – Expected values: SN 29500
-----------	--

Technical data sheet

Interface Technology · LCIS analog/analog converter

Failure rate at +45 °C	681 fit
Failure rate at +45 °C	1468511 h
	1 fit equals one failure per 10^9 component hours
	The indicated temperature is the mean component ambient temperature.
Comments	The results are valid under following conditions: Automotive environment or industrial areas without extreme dust levels and harmful substances Continuous operation 8760 h per year

Certifications/Standards

Conformity	CE UKCA
Certifications	cULus (E135145) DNV (TAA000024Y)
Standards	EN 60947-1 EN 60947-5-1 EN 61000-6-2 EN 61000-6-4 UL 508 DNV-CG-0339

Dimensions

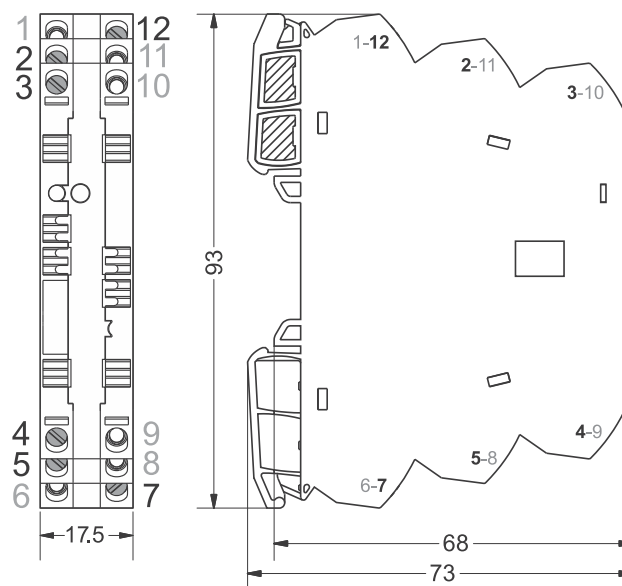

PIN assignment

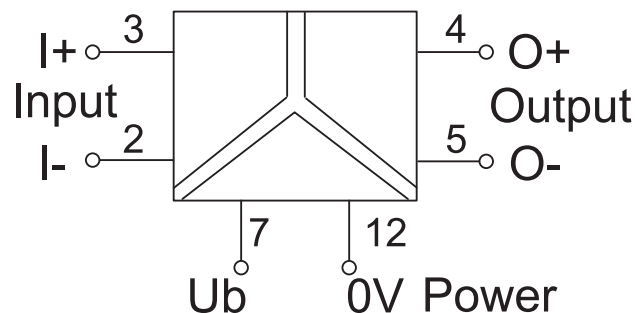

Technical data sheet

Interface Technology · LCIS analog/analog converter

Use

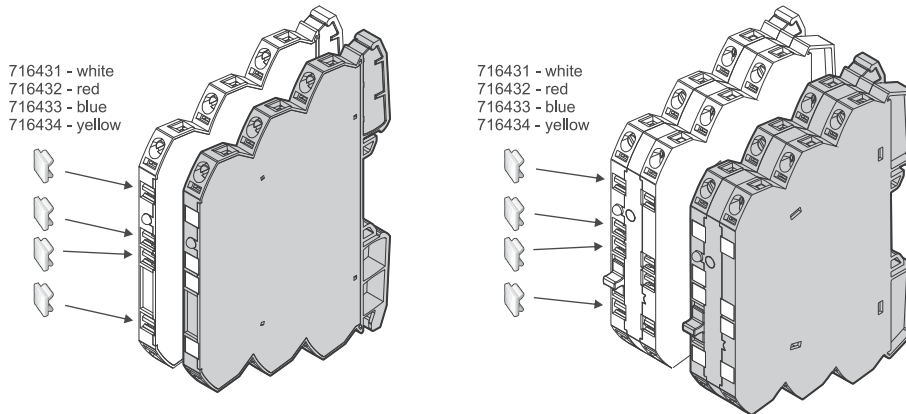

Use

DE DIP-Schalterstellungen EN DIP switch positions FR Positions des interrupteurs DIP

DE HINWEIS: Die Schalter dürfen während des Betriebs nicht umgeschaltet werden. Der Wandler benötigt einen Neustart.
EN NOTICE: The switches must not be switched during operation. The converter requires a restart.
FR AVIS: Les interrupteurs ne doivent pas être actionnés pendant le fonctionnement. Le convertisseur nécessite un redémarrage.

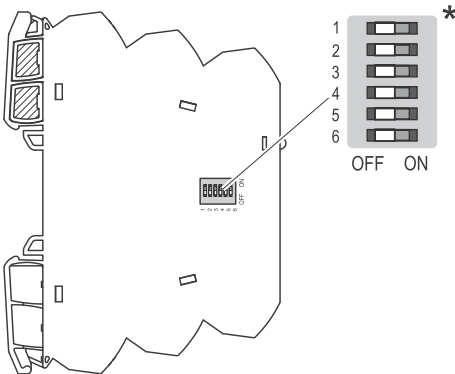

* **DE:** Auslieferungszustand (Werkseinstellung): 0-Einstellung/ alle Schalter sind auf OFF gestellt.
Je nach Art des Wandlers ist dann bereits ein bestimmter Bereich voreingestellt.

* **EN:** Delivery state (factory setting): 0 setting/ all switches are set to OFF.
Depending on the type of transducer, a certain range is then already preset.

* **FR:** État à la livraison (réglage d'usine) : réglage 0/ tous les interrupteurs sont sur OFF.
Selon le type de transducteur, une certaine plage est alors déjà prédéfinie.

750510.0000
 751510.0000
 751518.0000
 751519.0000
 750518.0000
 750519.0000

S1	Input	1	2	3	4
●→Switch On					
0- 10V*		●			
0-20mA		●			
4-20mA		●	●		

S1	Output	5	6
●→Switch On			
0- 10V*		●	
0-20mA		●	
4-20mA		●	●

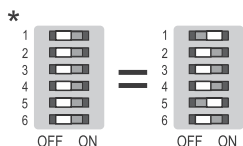

750516.0000
 750517.0000
 751516.0000
 751517.0000

S1	Input	1	2	3	4
●→Switch On					
0- 60 mV		●			
0- 100 mV		●			
0- 300 mV		●			
0- 500 mV		●	●		
0- 1 V		●	●		
0- 2 V		●	●		
0- 5 V		●	●	●	
0- 10 V*		●	●	●	
2- 10 V		●	●	●	●
0- 20 V		●	●	●	●
0- 5 mA		●	●	●	●
0- 10 mA		●	●	●	●
± 5 mA		●	●	●	●
± 20 mA		●	●	●	●
0- 20 mA		●	●	●	●
4- 20 mA		●	●	●	●

S1	Output	5	6
●→Switch On			
0- 10 V*		●	
0- 20 mA		●	
4- 20 mA		●	●

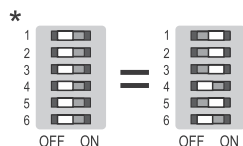

750512.0000
 751512.0000

S1	Input	1	2	3	4
●→Switch On					
0- 10 V*		●			
0- 20 mA		●			
4- 20 mA		●	●		

S1	Output	5	6
●→Switch On			
0- 50 Hz*		●	
0- 100 Hz		●	
0- 1000 Hz		●	●
0- 10000 Hz		●	●

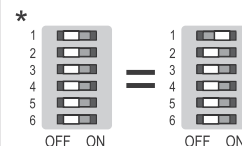

Technical data sheet

Interface Technology · LCIS analog/analog converter

Range adjustment

S1 ●→Switch On	Input			
	1	2	3	4
0-60 mV				
0-100 mV	●			
0-300 mV		●		
0-500 mV	●	●		
0-1 V			●	
0-2 V	●		●	
0-5 V		●	●	
0-10 V*	●	●	●	
2-10 V				●
0-20 V	●			●
0-5 mA		●	●	
0-10 mA	●	●	●	
±5 mA			●	●
±20 mA	●	●	●	●
0-20 mA		●	●	●
4-20 mA	●	●	●	●

S1 ●→Switch On	Output	
	5	6
0-10 V*	●	
0-20 mA		●
4-20 mA	●	●

