

## Technical data sheet

Interface Technology · LCIS analog/analog converter

---

Input: 0–10 V / 0–20 mA / 4–20 mA

Output: 0–10 kHz

Insulation: 2.5 kV, 3-way isolation



---

### Identification

Type	LCIS-WAF-0511-62-S
Part No.	<a href="#">750511.0000</a>

---

### Product version

Hardware revision	1.0
Software version	1.1
Datasheet version	01

---

### Input

Input signal	0–10 V, 0–20 mA, 4–20 mA, adjustable via DIP switch S1
Input variable	Analogue signals
Galvanic isolation I/O	3-way isolation
Zero /Span	Production comparison
Input resistance	>330 kΩ @ 0–10 V, <100 Ω @ 0–20 mA, 4–20 mA

---

### Output

Output signal	0–50 Hz, 0–100 Hz, 0–1 kHz, 0–10 kHz adjustable via DIP switch S1
Signal level	DC 24 V (DIN EN 61131-2) Type 1: ≥ 15 V (@ 2 mA) Type 2: ≥ 11 V (@ 6 mA)

---

### Operating data

Accuracy	0.1 % FSR @ 23 °C
Linearity error	0.05 % FSR

---

#### United Kingdom: LÜTZE Ltd.

Unit 3, Sandy Hill Park  
Sandy Way, Amington • GB-Tamworth, Staffs B77 4DU  
Tel. +44 (0)1827 31333-0 • Fax +44 (0)1827 31333-2  
[www.lutze.com](http://www.lutze.com) • [sales.gb@lutze.co.uk](mailto:sales.gb@lutze.co.uk)

#### Germany: Friedrich Lütze GmbH

Postfach 12 24 (PLZ 71366) • Bruckwiesenstraße 17-19 • D-71384 Weinstadt  
Tel. +49 (0)7151 6053-0 • Fax +49 (0)7151 6053-277(-288)  
[www.luetze.de](http://www.luetze.de) • [info@luetze.de](mailto:info@luetze.de)

12.12.2023 • Subject to technical modification  
Part No. [750511.0000](#) • Datasheet version: 01

## Technical data sheet

### Interface Technology · LCIS analog/analog converter

---

Rise time (10-90%)	frequency-dependent
Build-up time (Accuracy 1%)	frequency-dependent
Temperature coefficient	<150 ppm / K FSR
Critical frequency	30 Hz @ 3 dB

---

#### General

---

Rated voltage $U_N$	AC/DC 24 V
Current Consumption	26 mA
Current consumption at 24 V	at AC 24V: 26 mA (station supply)
Status indication	LED green
Input/output protection	Overvoltage, current input with PTC fuse, short circuit-proof output
Insulation voltage input / output	2.5 kV <sub>eff</sub>
Housing material	PA 6.6 (UL 94 V-0, NFF I2, F2)
Color of the housing	RAL 7012 basalt grey
Mounting	DIN rail mountable TS35 (EN 60715)
Degree of protection	IP20
Installation position	Any
Connection type	Screwed terminal single wire 0.25 mm <sup>2</sup> – 2.5 mm <sup>2</sup> / AWG 24–14 fine stranded wire with ferrule 0.25 mm <sup>2</sup> – 1.5 mm <sup>2</sup> / AWG 24–16
Strip length	8 mm
Dimensions (w × h × d)	6.2 mm × 93.0 mm × 73.0 mm
Weight/unit	0.029 kg
PU (units)	1

---

#### General ambient conditions

---

Operation temperature range	-25 °C ... +60 °C
Storage temperature range	-40 °C ... +85 °C
Relative air humidity	20 – 90 % RH, not condensing
Vibration resistance	0.7 g acc. to EN 60068-2-6

---

#### Failure Rate Prediction (MTBF)

---

Standards	Electronic components – Reliability – Reference conditions for failure rates and stress models for conversion: EN/IEC 61709 Failure Rates of Components – Expected values: SN 29500
Failure rate at +45 °C	667 fit
Failure rate at +45 °C	1498305 h 1 fit equals one failure per 10 <sup>9</sup> component hours
Comments	The indicated temperature is the mean component ambient temperature. The results are valid under following conditions: Automotive environment or industrial areas without extreme dust levels and harmful substances Continuous operation 8760 h per year

---

## Technical data sheet

### Interface Technology · LCIS analog/analog converter

#### Certifications/Standards

Conformity	CE UKCA
Certifications	cULus (E135145) DNV (TAA000024Y)
Standards	EN 60947-1 EN 60947-5-1 EN 61000-6-2 EN 61000-6-4 UL 508 DNV-CG-0339

#### Dimensions

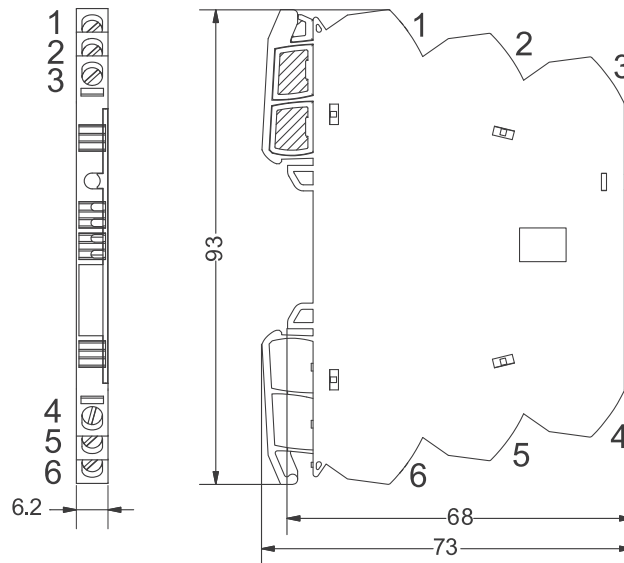

#### PIN assignment

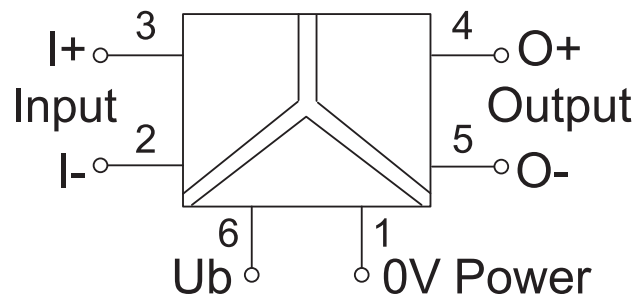

# Technical data sheet

## Interface Technology · LCIS analog/analog converter

### Use

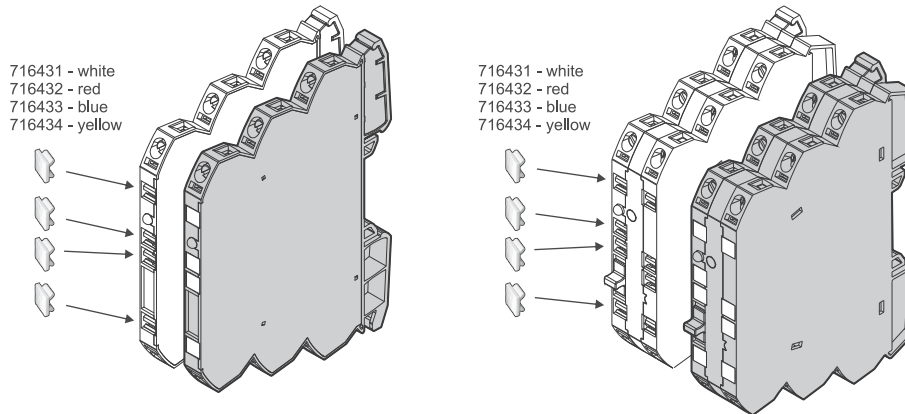

### Use

**DE HINWEIS:** Die Schalter dürfen während des Betriebs nicht umgeschaltet werden. Der Wandler benötigt einen Neustart.  
**EN NOTICE:** The switches must not be switched during operation. The converter requires a restart.  
**FR AVIS:** Les interrupteurs ne doivent pas être actionnés pendant le fonctionnement. Le convertisseur nécessite un redémarrage.

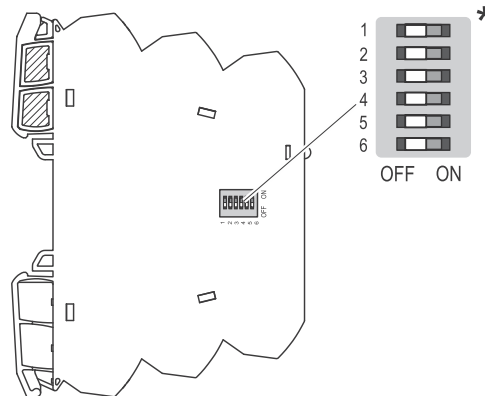

- \* DE: Auslieferungszustand (Werkseinstellung): 0-Einstellung/ alle Schalter sind auf OFF gestellt.
- \* EN: Delivery state (factory setting): 0 setting/ all switches are set to OFF.
- \* FR: État à la livraison (réglage d'usine) : réglage 0/ tous les interrupteurs sont sur OFF.

### Range adjustment

S1	Input
● → Switch On	1 2 3 4
0–10 V*	●
0–20 mA	●
4–20 mA	● ●

S1	Output
● → Switch On	5 6
0–50 Hz*	
0–100 Hz	●
0–1000 Hz	●
0–10000 Hz	● ●

